

ASOU 130 آسو

Lift & Sliding system

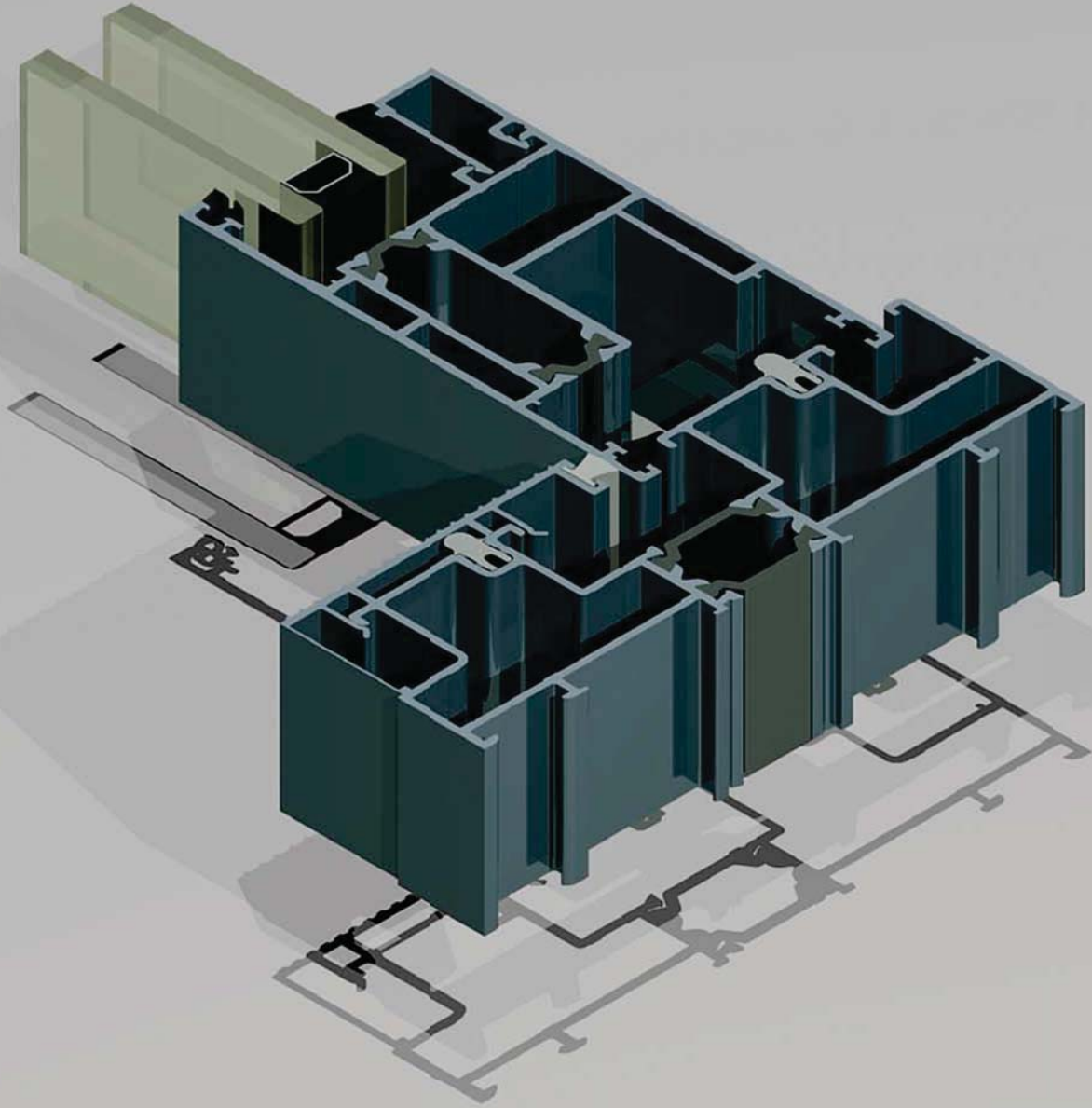

INOPEX
Innovated Profile Extrusion

سال 27 تجربه

YEARS OF EXPERIENCE



شرکت قالب سازی ایران قدر شقایق (سهامی خاص) فعالیت خود را از مهرماه سال ۱۳۷۰ با مجموعه‌ای از کارشناسان خیره و دارای تجربه در زمینه ساخت قالب‌های اکستروژن، تولید انواع مقاطع آلیاژهای آلومینیومی و ارائه خدمات مهندسی در زمینه سازی پرس‌های اکستروژن شروع نمود. در سال ۱۳۷۳ با راه اندازی فرز CNC و وایرکات CNC برای اولین بار در ایران ساخت قالب‌های اکستروژن آلومینیوم را در کارخانه خود با روش cad / cam بهینه نمود. در سال ۱۳۸۵ با نصب و راه اندازی پرس اکستروژن ۲۰۰۰ تنی مستقیم / غیرمستقیم سنبه دار ساخت شرکت شلومن آلمان مجهز به سیستم پولر و میزهای اتوماتیک تسمه‌های نسوز، تنوع و کیفیت تولیدات خود را ارتقا داده است. و تولید لوله‌های بدون درز (Seam less) با آلیاژهای سخت آلومینیوم را در محصولات خود گنجانده است. و هم اکنون شرکت شقایق با ارائه خدمات طراحی سیستم‌های یکپارچه و مقاطع مورد نیاز مصرف کنندگان با ساخت قالب و تولید پروفیل مربوطه برای مشتریان خود اطمینان خاطر را به ارمغان آورده است. کسب سه دوره متوالی (شش سال) برند برتر تولید مقاطع صنعتی از سندیکای صنایع آلومینیوم ایران موید تلاش این شرکت در جهت حفظ کیفیت مقاطع تولیدی می‌باشد.

از سال ۱۳۹۴ شرکت شقایق طراحی و تولید مقاطع در و پنجره‌های آلومینیومی شمال بریک و غیر شمال بریک را در دستور کار خود قرار داده و در این راستا با استفاده از دانش فنی نیروهای متخصص داخلی و تجربیات بین‌المللی دستاوردهای بزرگی را تجربه کرده که نمونه‌های آن را میتوانید در این کاتالوگ ملاحظه فرمایید.

حداکثر ابعاد ساخت بر اساس فشار باد

Wind load dimensional diagram

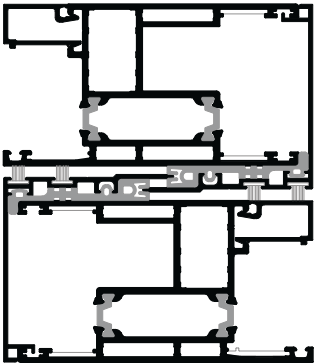
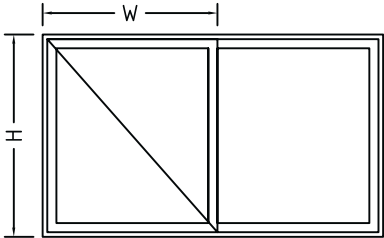
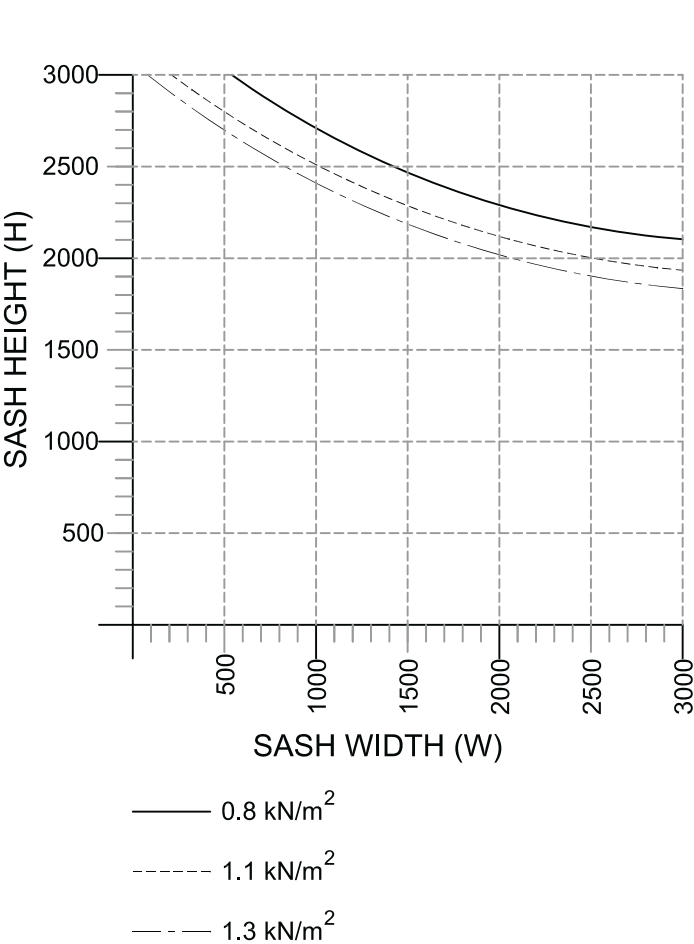

NOTES:

Max. Deflection = 12mm. in accordance with EN1279-5
 Max. Sash weight = 300 kg

حداکثر ابعاد ساخت بر اساس فشار باد
Wind load dimensional diagram

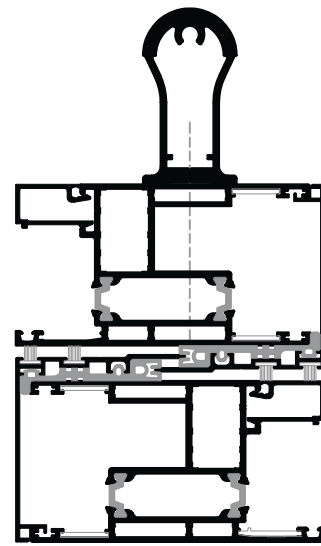
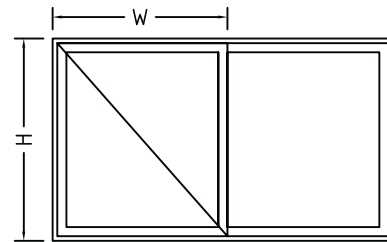
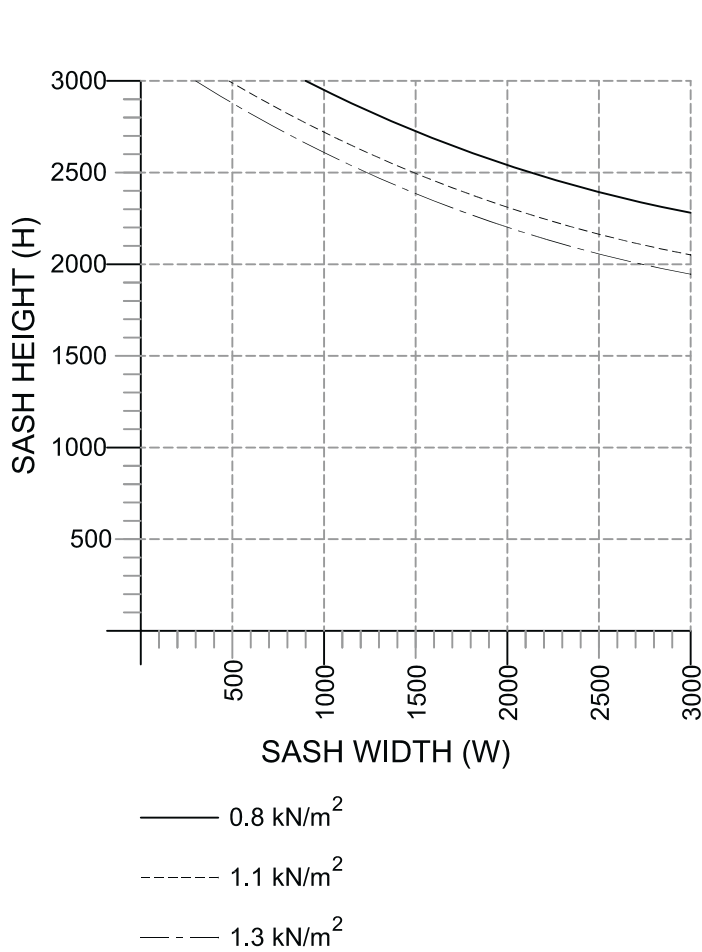

NOTES:

- Max. Deflection = 12mm. in accordance with EN1279-5
- Max. Sash weight = 300 kg

حداکثر ابعاد ساخت بر اساس فشار باد

Wind load dimensional diagram

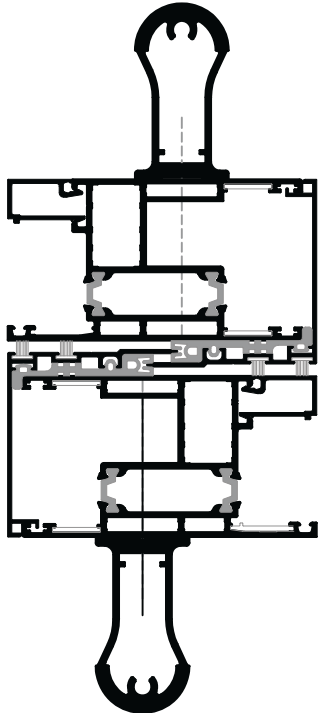
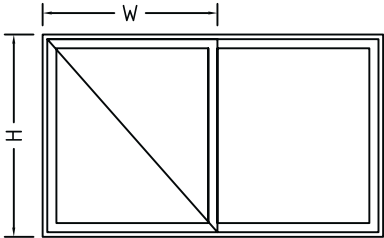
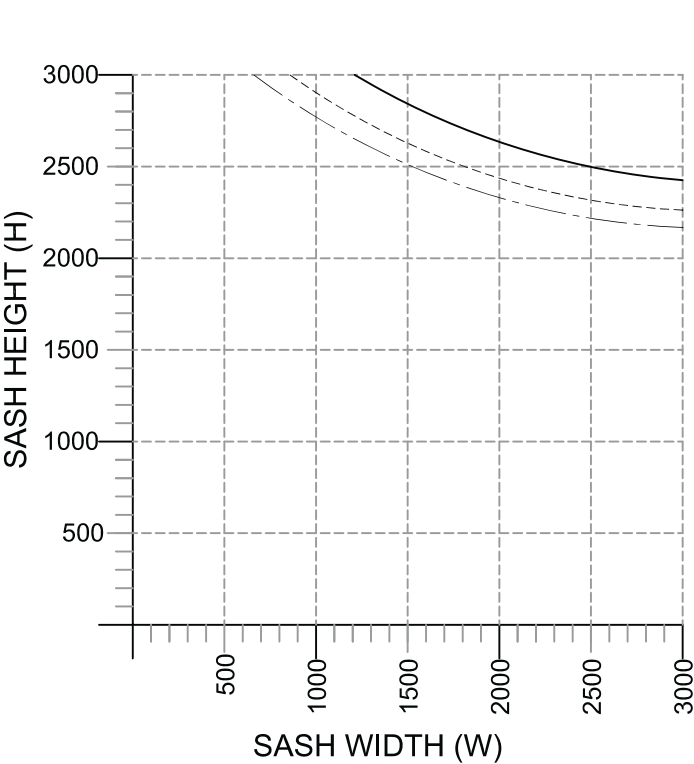

NOTES:

Max. Deflection = 12mm. in accordance with EN1279-5
 Max. Sash weight = 300 kg

Notes:

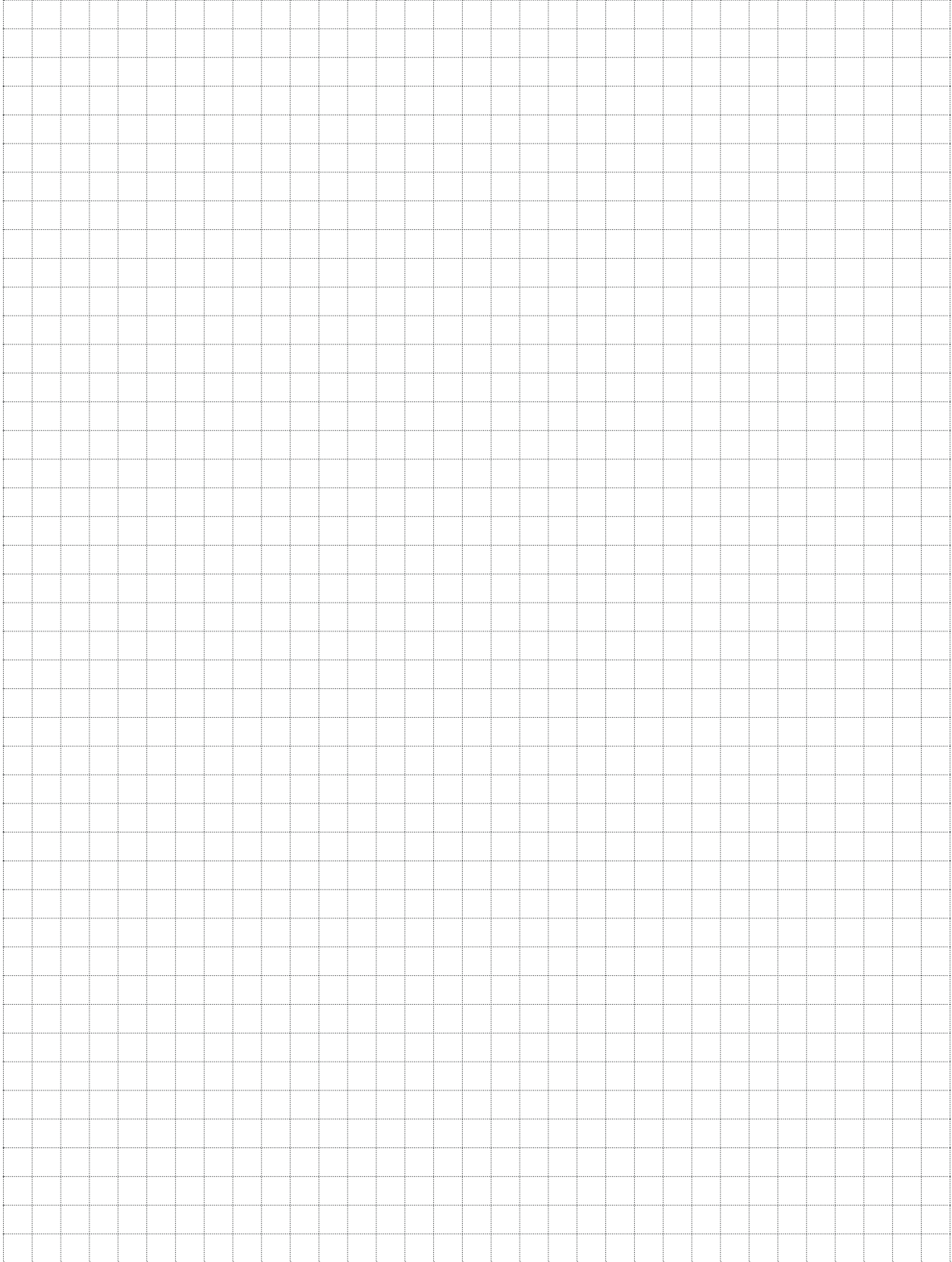



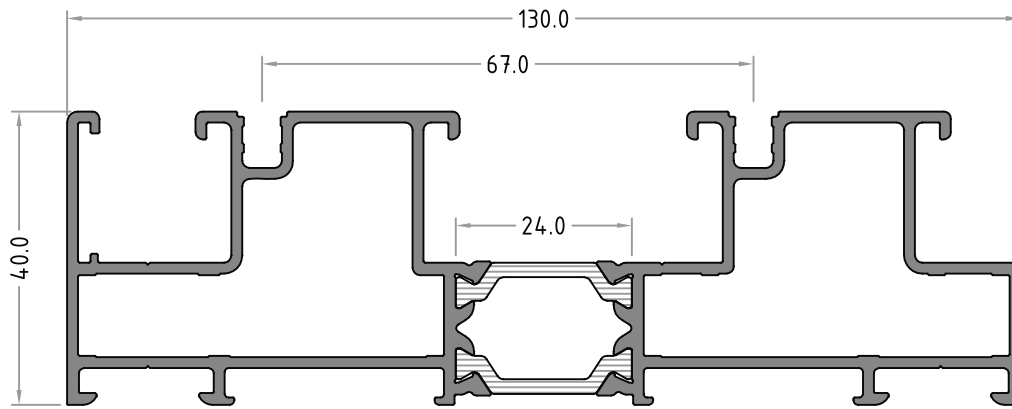

ASOU 130 Lift & Slide System



2111302

Frame profile 40/40

پروفیل فریم دو ریل ۴۰/۴۰



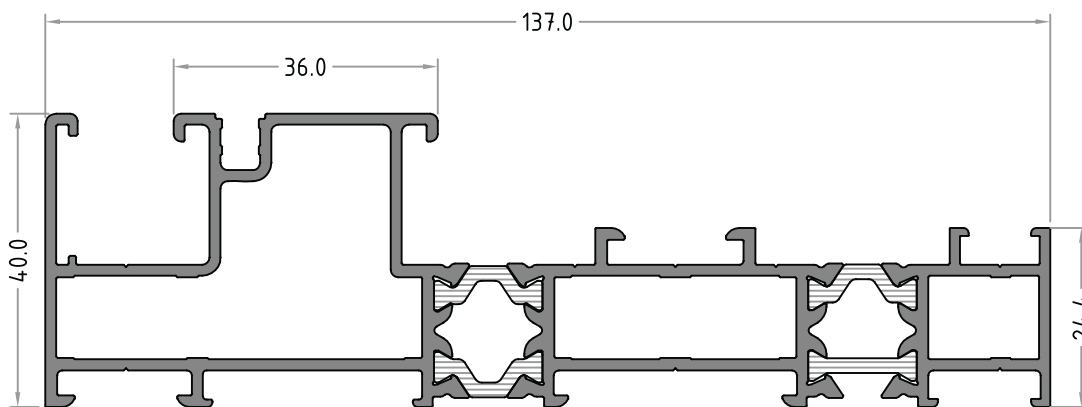

	2.139 kg/m	
	5387495	5387495
	7501020	
	6.00 meter	



2111303

Frame profile 40/24

پروفیل فریم مونوریل ۴۰/۲۴

	2.334 kg/m		
	5387495	5387326	5387147
	7501020		
	6.00 meter		

سیستم لیفت اسلاید آسو ۱۳۰

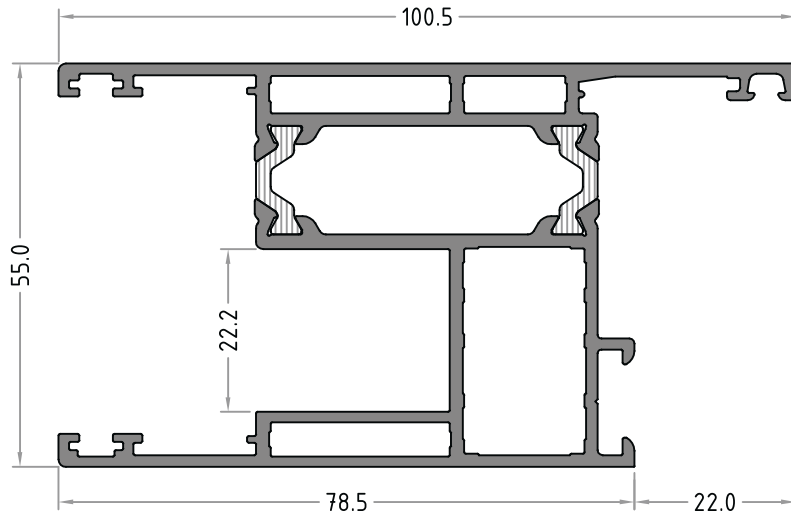

2211301

Sash profile 100/78

پروفیل لنگه ۱۰۰/۷۸

	2.125 kg/m		
	5301267	5196044	5196044
	7501011	4901002	4901002
	6.00 meter		

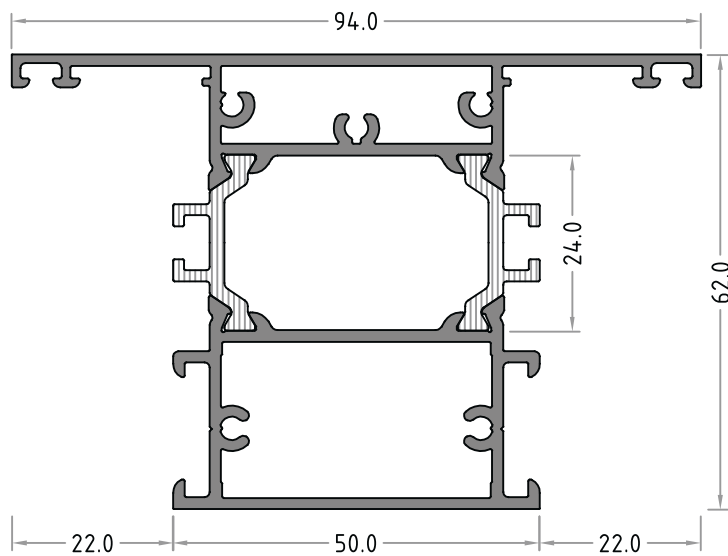

2416204

Mullion/Transom 94/50 /Screw

پروفیل وادار ۹۴/۵۰ با پیچ

	1.850 kg/m		
	6.00 meter		

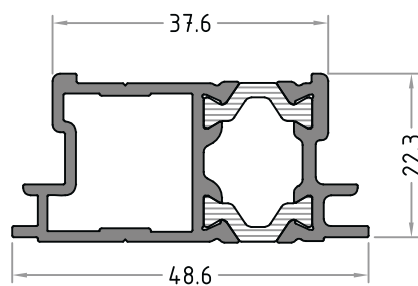

2611301

Meeting Profile

پروفیل وسط چهار لنگه

	0.789 kg/m		
	6.00 meter		

ASOU 130 Lift & Slide System

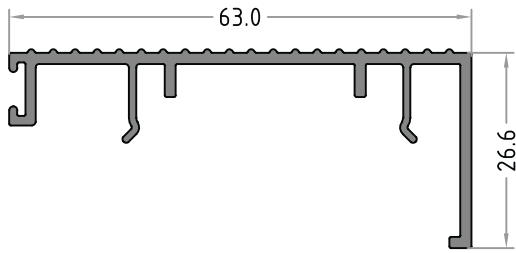

1000491	
Frame Cover	
پروفیل پاخور فریم دو ریل	
	0.528 kg/m
	6.00 meter

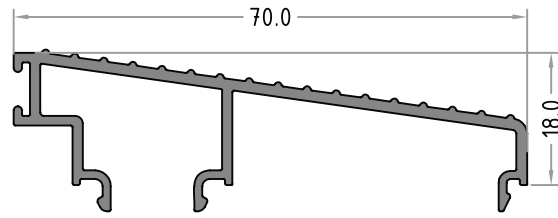

1000515	
Frame Cover	
پروفیل پاخور فریم مونو ریل	
	0.546 kg/m
	6.00 meter

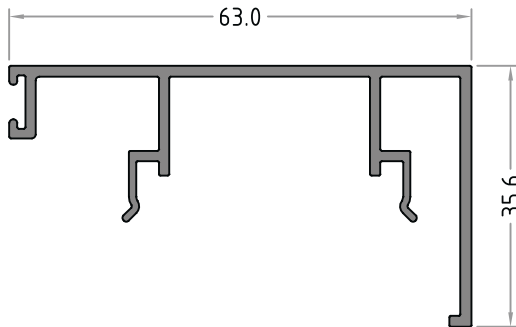

1000492	
Frame Cover	
درپوش فریم دو ریل	
	0.625 kg/m
	6.00 meter

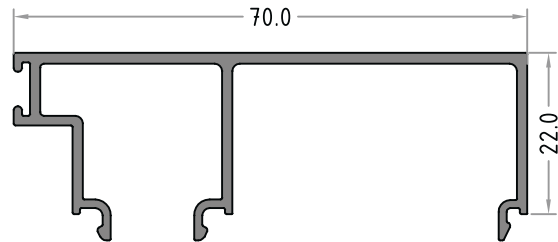

1000500	
Frame Cover	
درپوش فریم مونو ریل	
	0.620 kg/m
	6.00 meter

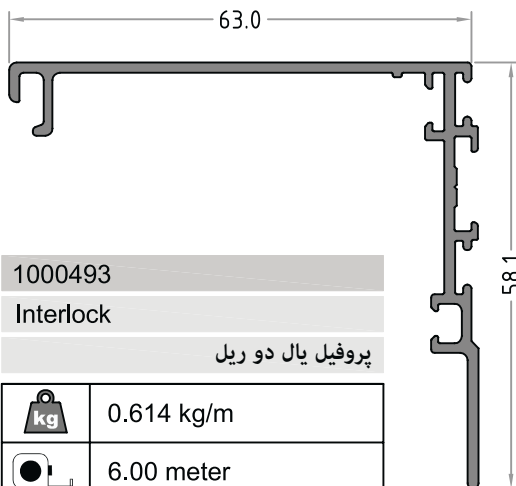

1000493	
Interlock	
پروفیل یال دو ریل	
	0.614 kg/m
	6.00 meter

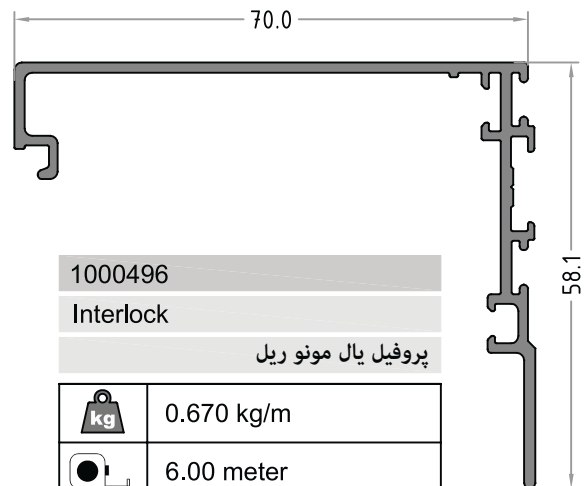

1000496	
Interlock	
پروفیل یال مونو ریل	
	0.670 kg/m
	6.00 meter

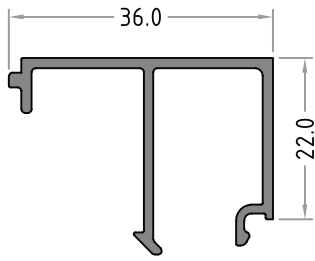

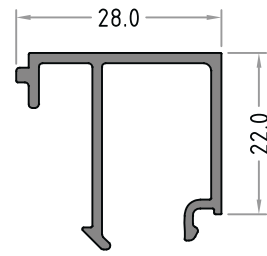

1000467	
Glazing Bead 36mm. 14/18	
زهوار ۳۶ میلیمتر پایه ۱۴/۱۸	
	0.360 kg/m
	6.00 meter

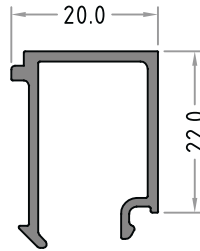

1000414	
Glazing Bead 28mm. 14/18	
زهوار ۲۸ میلیمتر پایه ۱۴/۱۸	
	0.330 kg/m
	6.00 meter



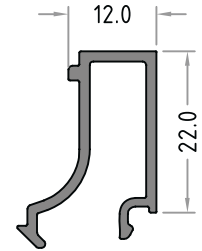

1000405	
Glazing Bead 20mm. 14/18	
زهوار ۲۰ میلیمتر پایه ۱۴/۱۸	
	0.280 kg/m
	6.00 meter

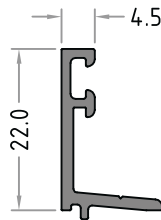

1000409	
Glazing Bead 12mm. 14/18	
زهوار ۱۲ میلیمتر پایه ۱۴/۱۸	
	0.265 kg/m
	6.00 meter



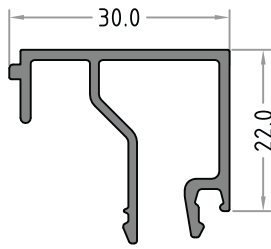

1000499	
Add on glazing bead	
زهوار شیشه بیرون	
	0.175 kg/m
	6.00 meter

ASOU 130 Lift & Slide System



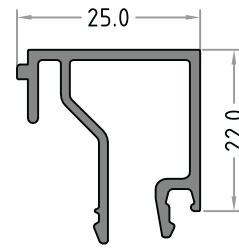

1000208	
Glazing Bead 30mm. 10/14	
زهوار ۳۰ میلیمتر پایه ۱۰/۱۴	
	0.359 kg/m
	6.00 meter



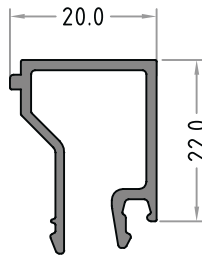

1000194	
Glazing Bead 25mm. 10/14	
زهوار ۲۵ میلیمتر پایه ۱۰/۱۴	
	0.340 kg/m
	6.00 meter



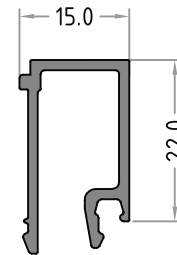

1000285	
Glazing Bead 20mm. 10/14	
زهوار ۲۰ میلیمتر پایه ۱۰/۱۴	
	0.291 kg/m
	6.00 meter

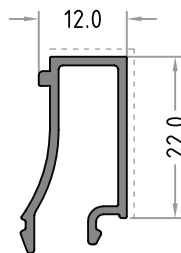

1000286	
Glazing Bead 15mm. 10/14	
زهوار ۱۵ میلیمتر پایه ۱۰/۱۴	
	0.270 kg/m
	6.00 meter



1000213	
Glazing Bead 12mm. 10/14	
زهوار ۱۲ میلیمتر پایه ۱۰/۱۴	
	0.222 kg/m
	6.00 meter

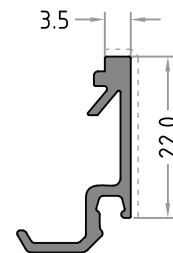

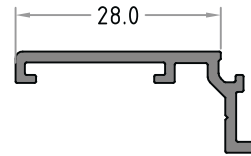

1000334	
Glazing Bead 5mm. 10/14	
زهوار ۵ میلیمتر پایه ۱۰/۱۴	
	0.215 kg/m
	6.00 meter



1000461

Round Shape Rail



پروفیل ریل گرد

 0.132 kg/m
 6.00 meter

1000501

Add on Profile

پروفیل لبه دور

 0.210 kg/m
 6.00 meter

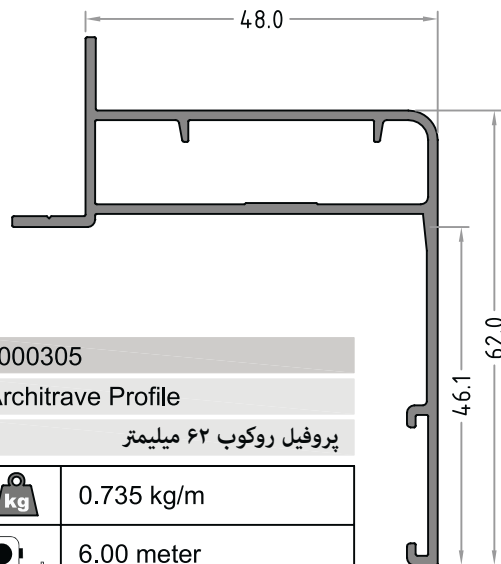
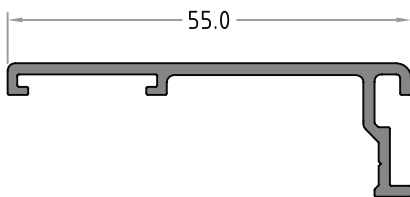

1000488

Architrave Profile

پروفیل روکوب ۵۵ میلیمتر

 0.360 kg/m
 6.00 meter

1000305

Architrave Profile

پروفیل روکوب ۶۲ میلیمتر

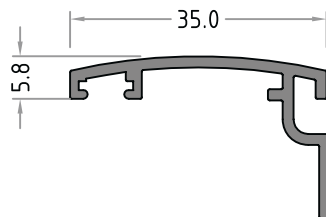

 0.735 kg/m
 6.00 meter











1000161

Architrave Profile

پروفیل روکوب ۳۵ میلیمتر

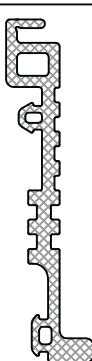
 0.290 kg/m
 6.00 meter

ASOU 130 Lift & Slide System

SYSTEM GASKETS			
لاستیک‌های سیستم			
Outer Glazing Gasket		7001001	لاستیک بیرونی شیشه
8 - 9 mm. Inner Glazing Gasket		7001002	لاستیک داخلی شیشه ۸-۹ میلیمتر
6 - 7 mm. Inner Glazing Gasket		7001005	لاستیک داخلی شیشه ۶-۷ میلیمتر
4 - 5 mm. Inner Glazing Gasket		7001034	لاستیک داخلی شیشه ۴-۵ میلیمتر
10 - 11 mm. Inner Glazing Gasket		7001062	لاستیک داخلی شیشه ۱۰-۱۱ میلیمتر
Thermal separator Gasket		7001043	لاستیک جدا کننده حرارتی
Screw Cover Gasket		7001058	لاستیک پوشش یال
Sash Weather Seal Gasket		7001065	لاستیک هوابندی لنگه
Frame Weather Seal Gasket		7011066	لاستیک هوابندی دور فریم
Weather Pile		7906807	موی ۷ میلیمتر

Notes:

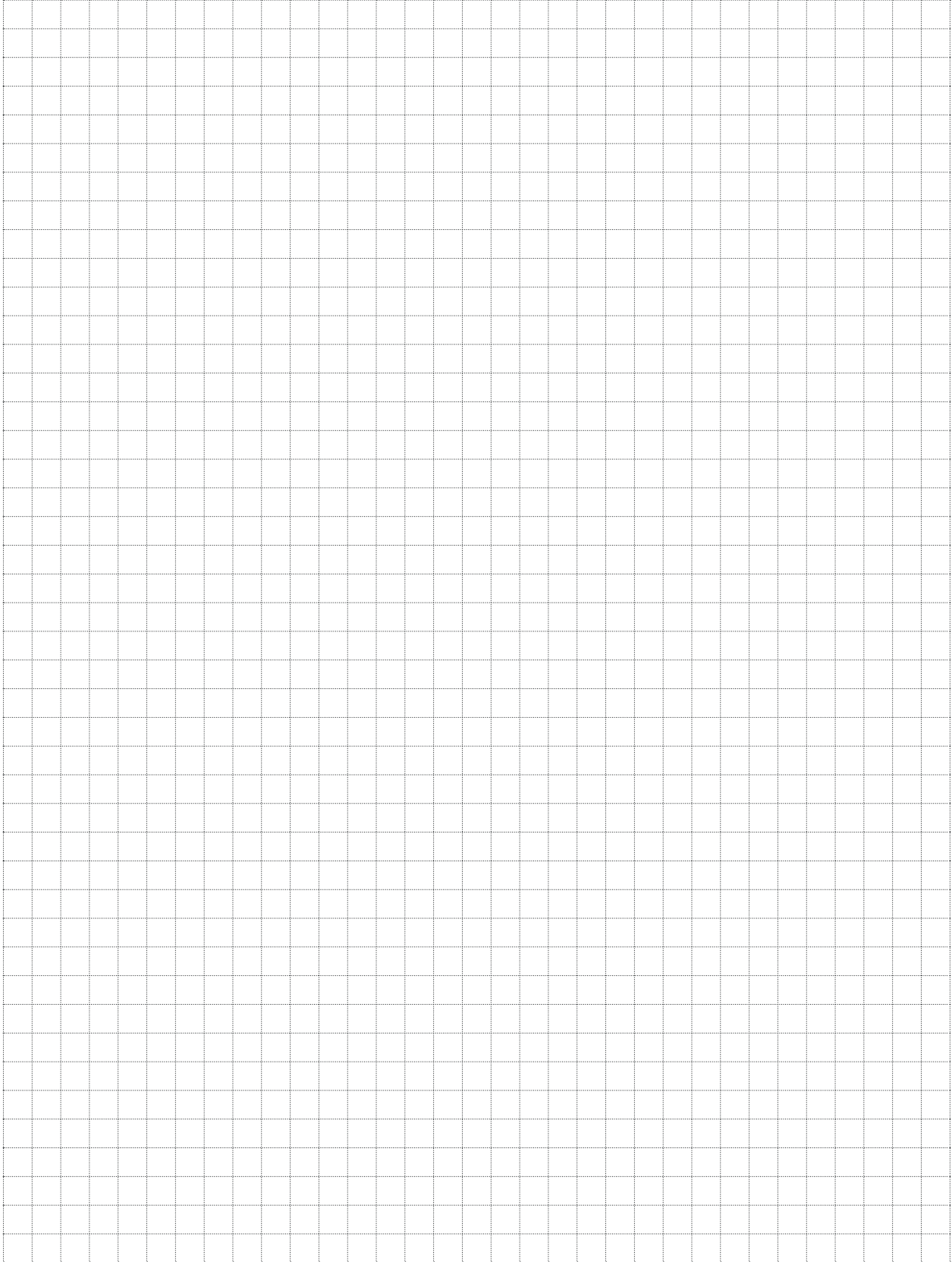

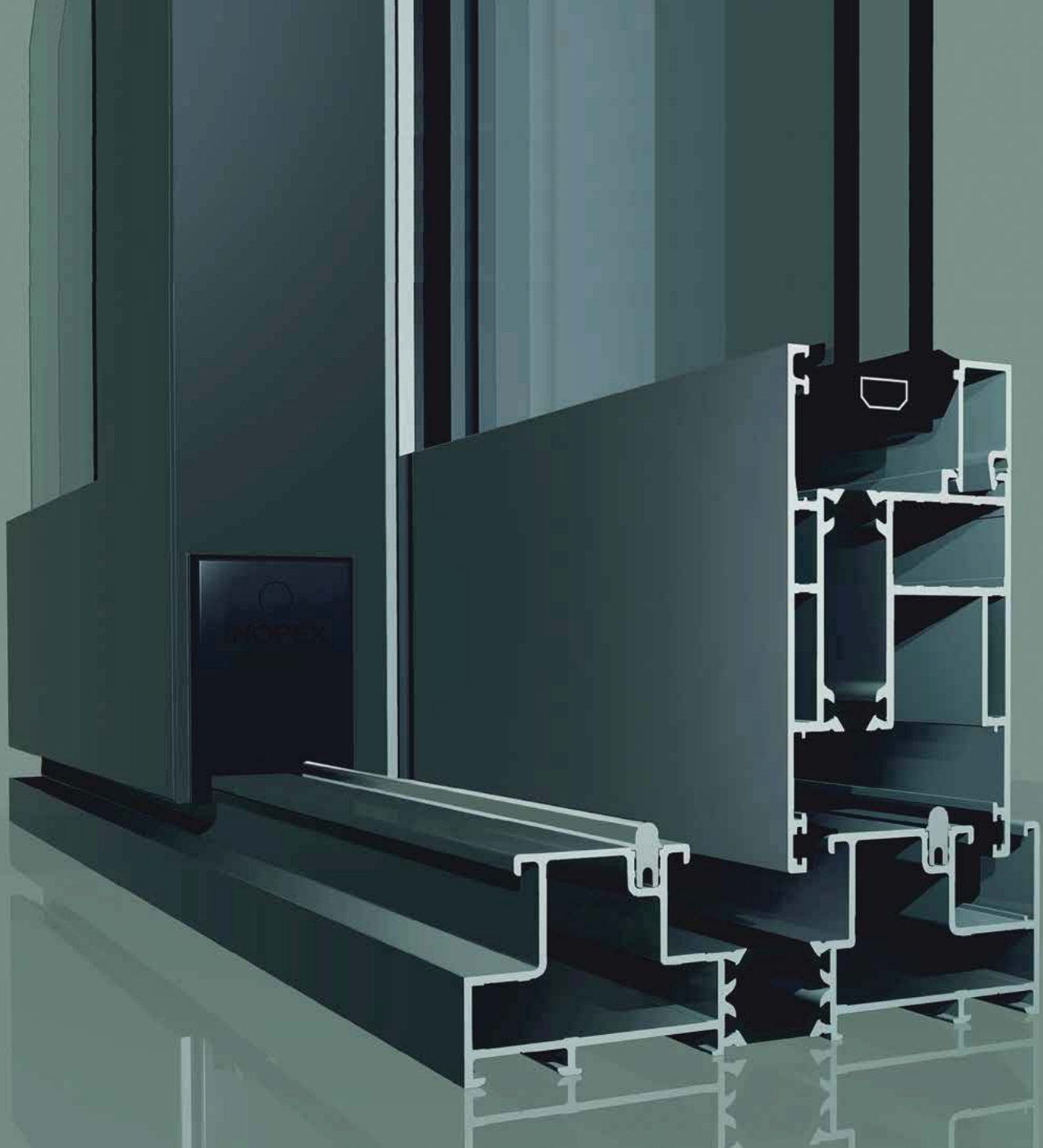

INOPEX
Innovated Profile Extrusion

ASOU 130

DUAL RAIL LIFT & SLIDE SYSTEM

آسو 130

سیستم لیفت اسلاید دو ریل

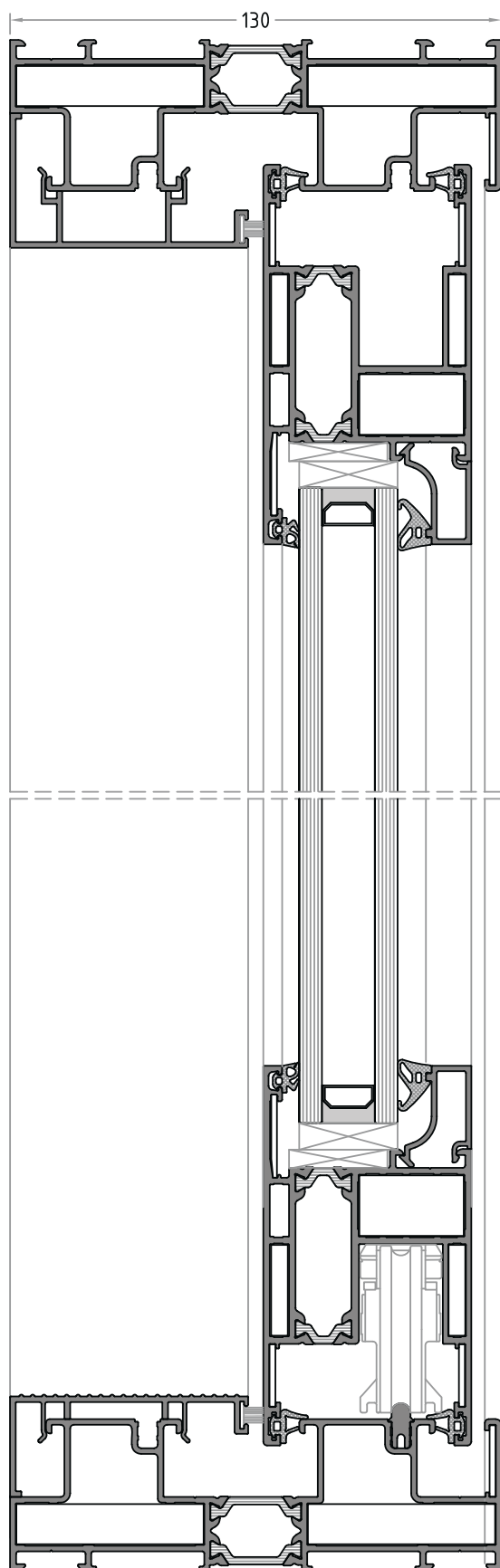

سیستم لیفت اسلاید یک سیستم کشویی با مکانیزم بلند شدن لنگه به مقدار حدود ۸ میلیمتر از محل استقرار در حالت قفل و سپس حرکت روی ریل می‌باشد. این عملکرد باعث شده در هنگام قفل کردن لنگه لاستیک‌های اطراف آن با فریم پنجره بصورت کامل درگیر شده و هوا بند می‌شود و در حال حرکت با بالا آمدن لنگه درگیری لاستیک‌ها به صفر رسیده و در نتیجه حرکت لنگه براحتی انجام می‌شود.

در سیستم آسو ۱۳۰ علاوه بر هوا بندی فوق پروفیل‌های طراحی شده در قسمت بیرون فریم، حداکثر هوا بندی ممکن را امکان‌پذیر می‌سازند.

در این سیستم یراق الات استاندارد ۳۰۰ و ۴۰۰ کیلویی برای هر لنگه قابل نصب بوده و حداکثر ابعاد قابل ساخت در دیاگرام‌های مندرج در این کاتالوگ در شرایط مختلف نشان داده شده است.

Lift & slide system categorized as a sliding system which have the capability of lifting around 8mm. and then sliding. This function will result complete weather sealing in lock position and easy movement in unlock position while the sash lifting up and the friction between gaskets and frame comes to almost zero.

In ASOU130 system in addition to weathering through gaskets, designed add on profiles on frame will increase the weather barrier and cause maximum performance.

The system has the capability of using 300kg and 400kg standard accessories. Maximum fabrication sizes shown in the diagrams in this catalogue.

ASOU 130 Lift & Slide System

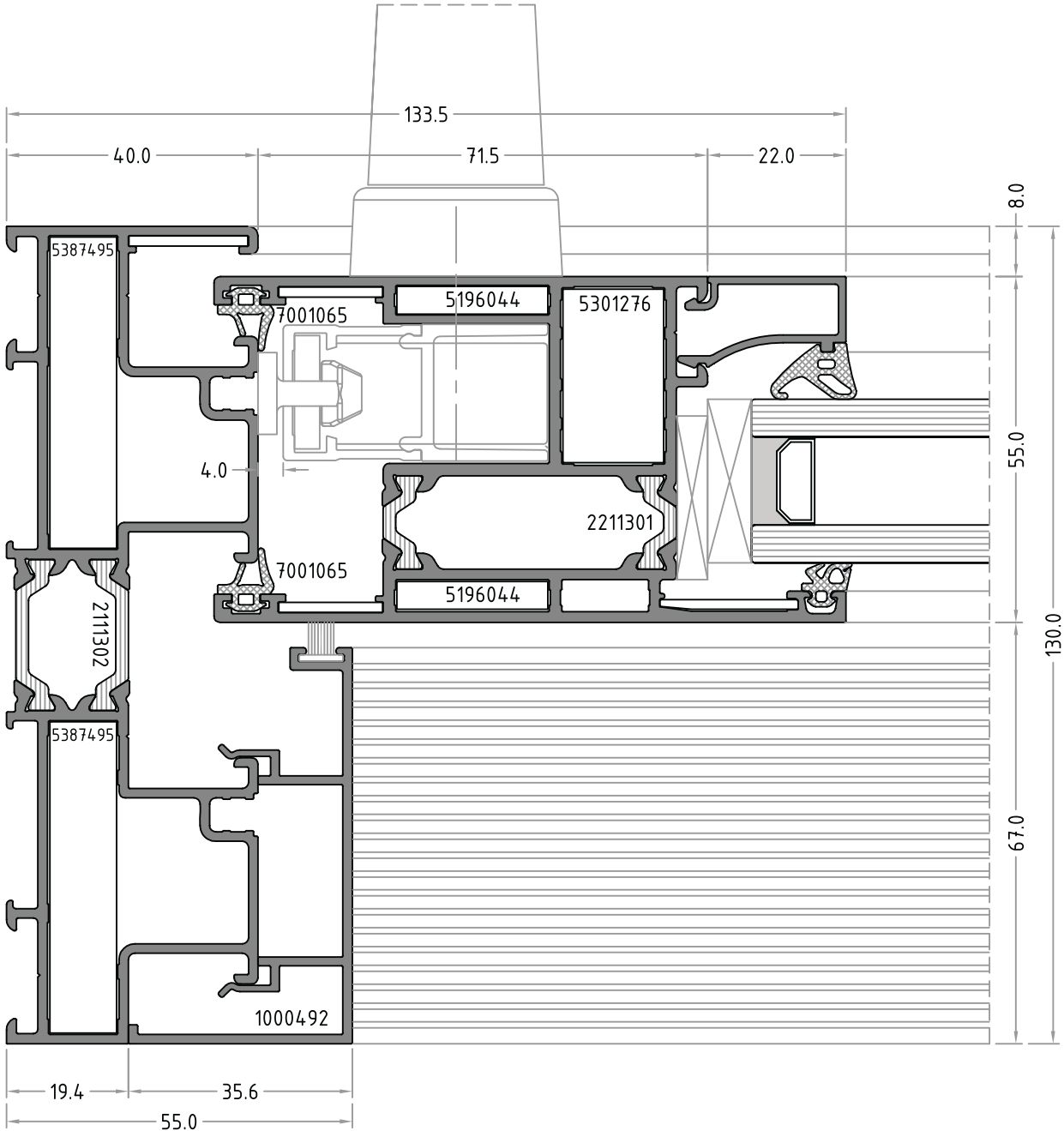
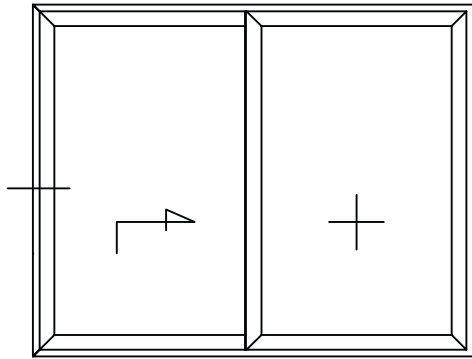

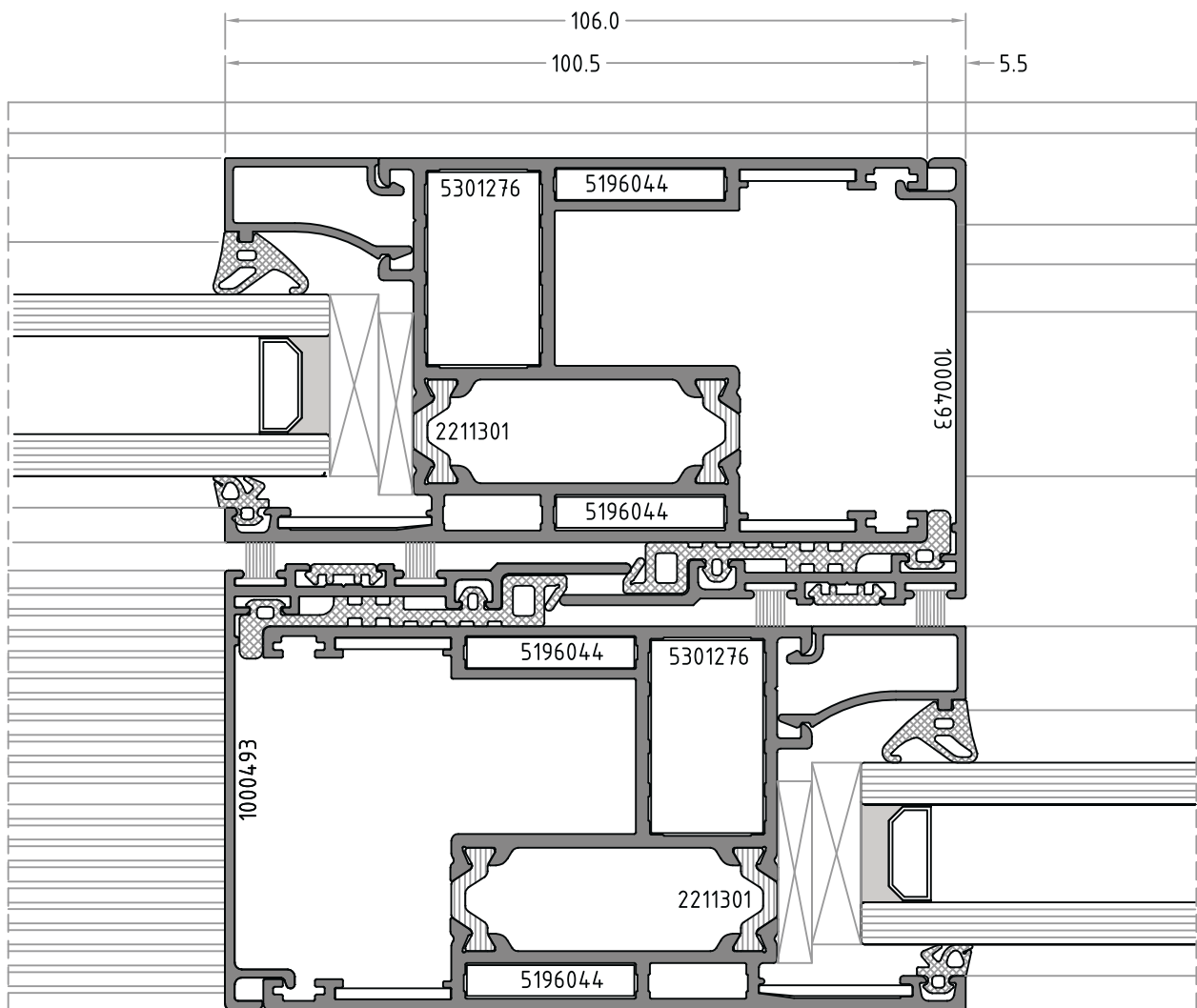
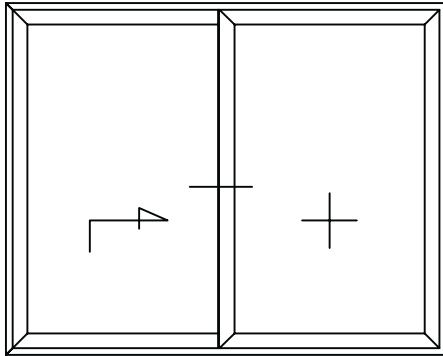

ASOU 130 Dual Rail

ASOU 130 Lift & Slide System

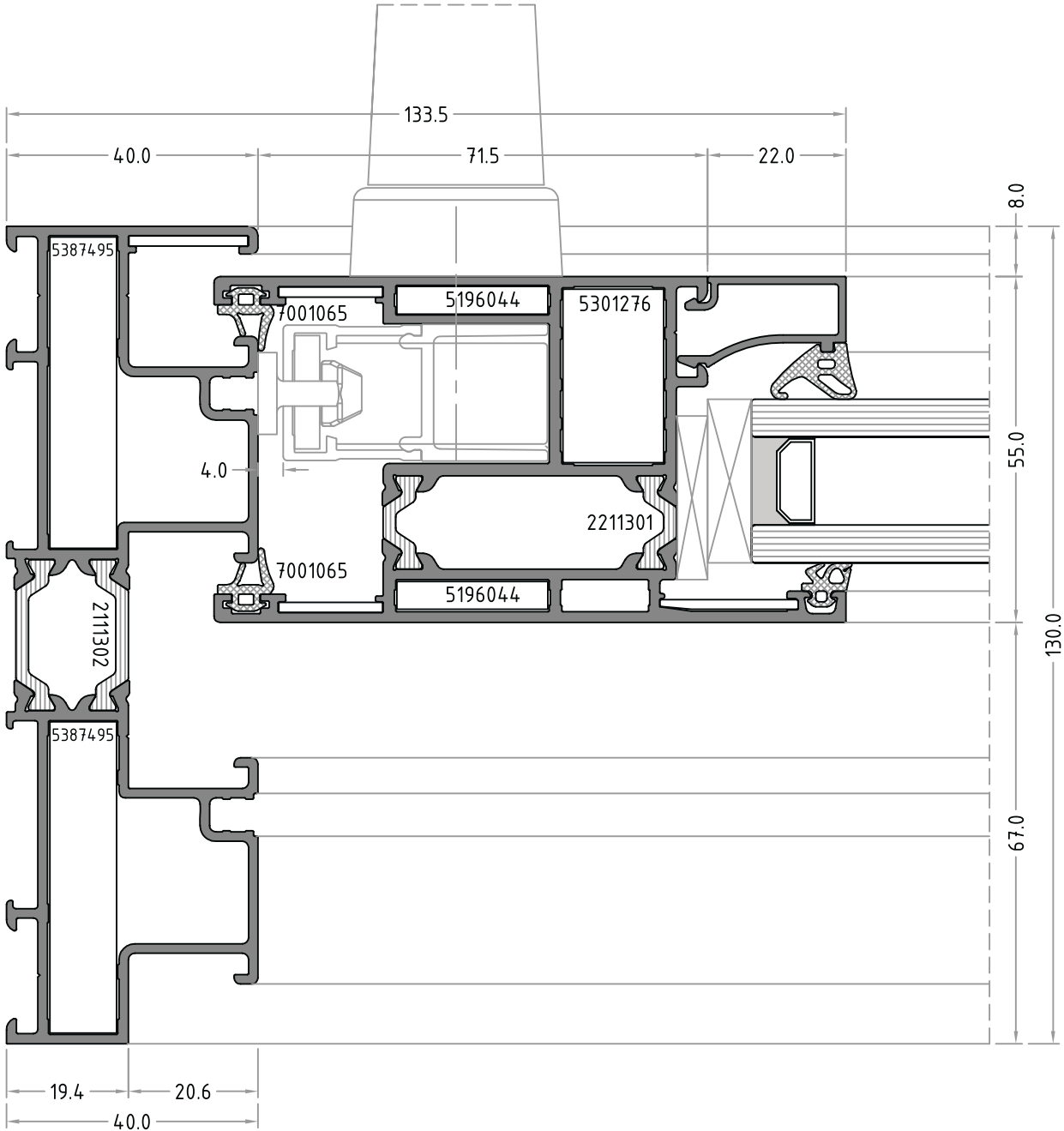
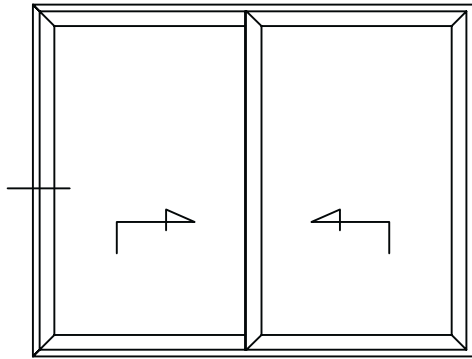

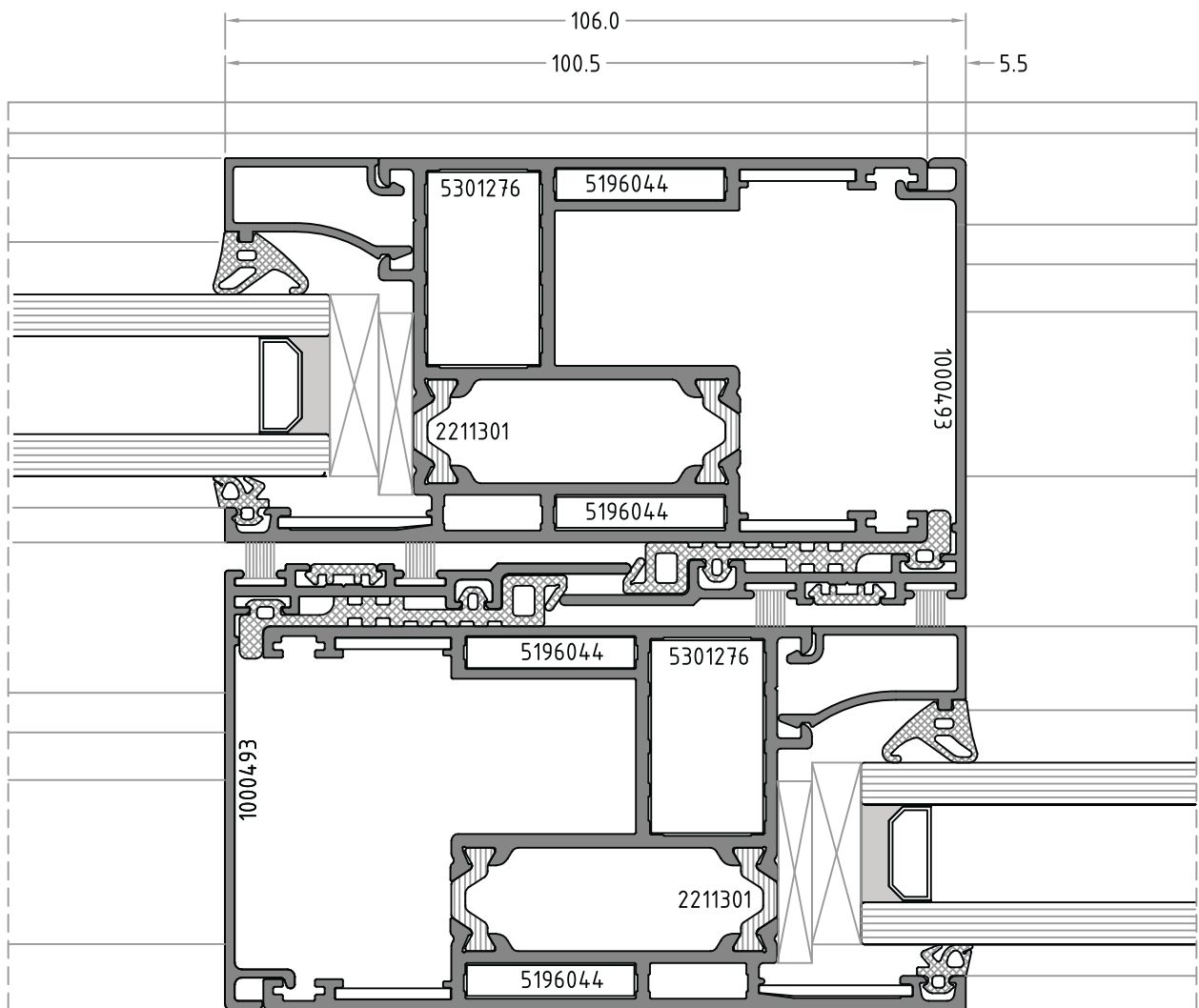
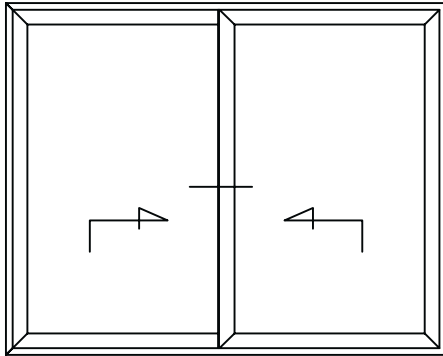

ASOU 130 Dual Rail

ASOU 130 Lift & Slide System

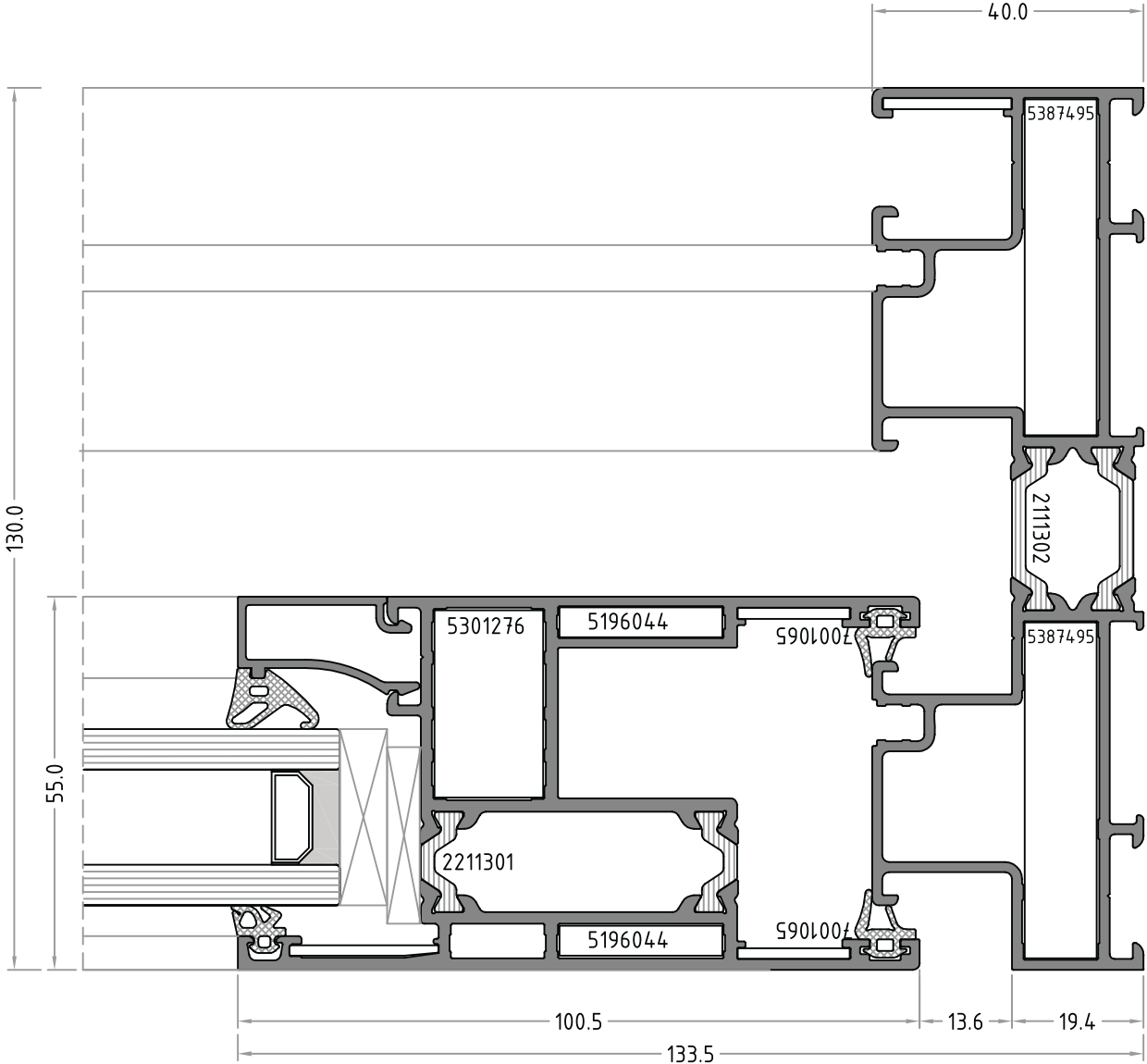
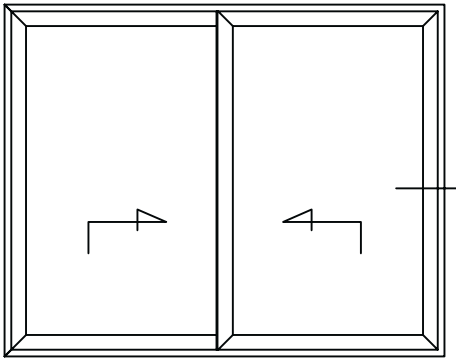
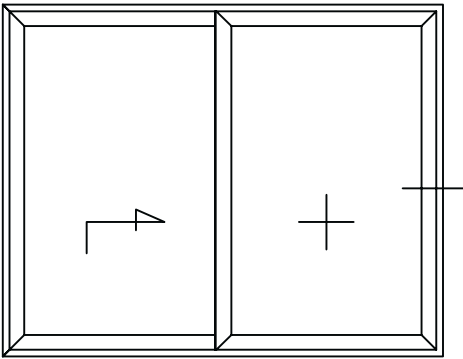

سیستم لیفت اسلاید آسو ۱۳۰

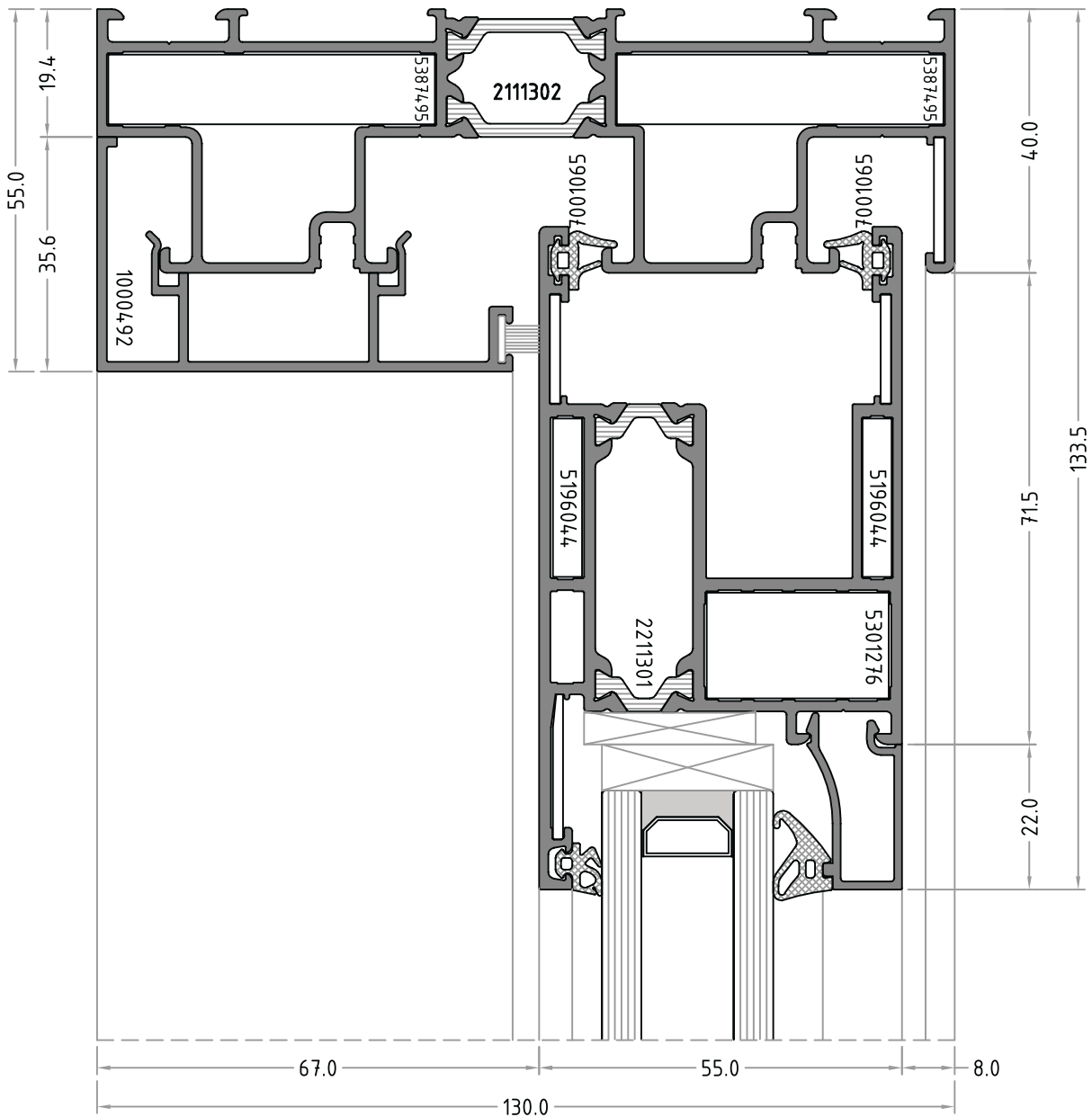
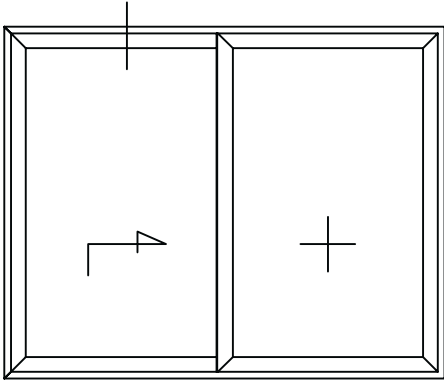

ASOU 130 Dual Rail

ASOU 130 Lift & Slide System

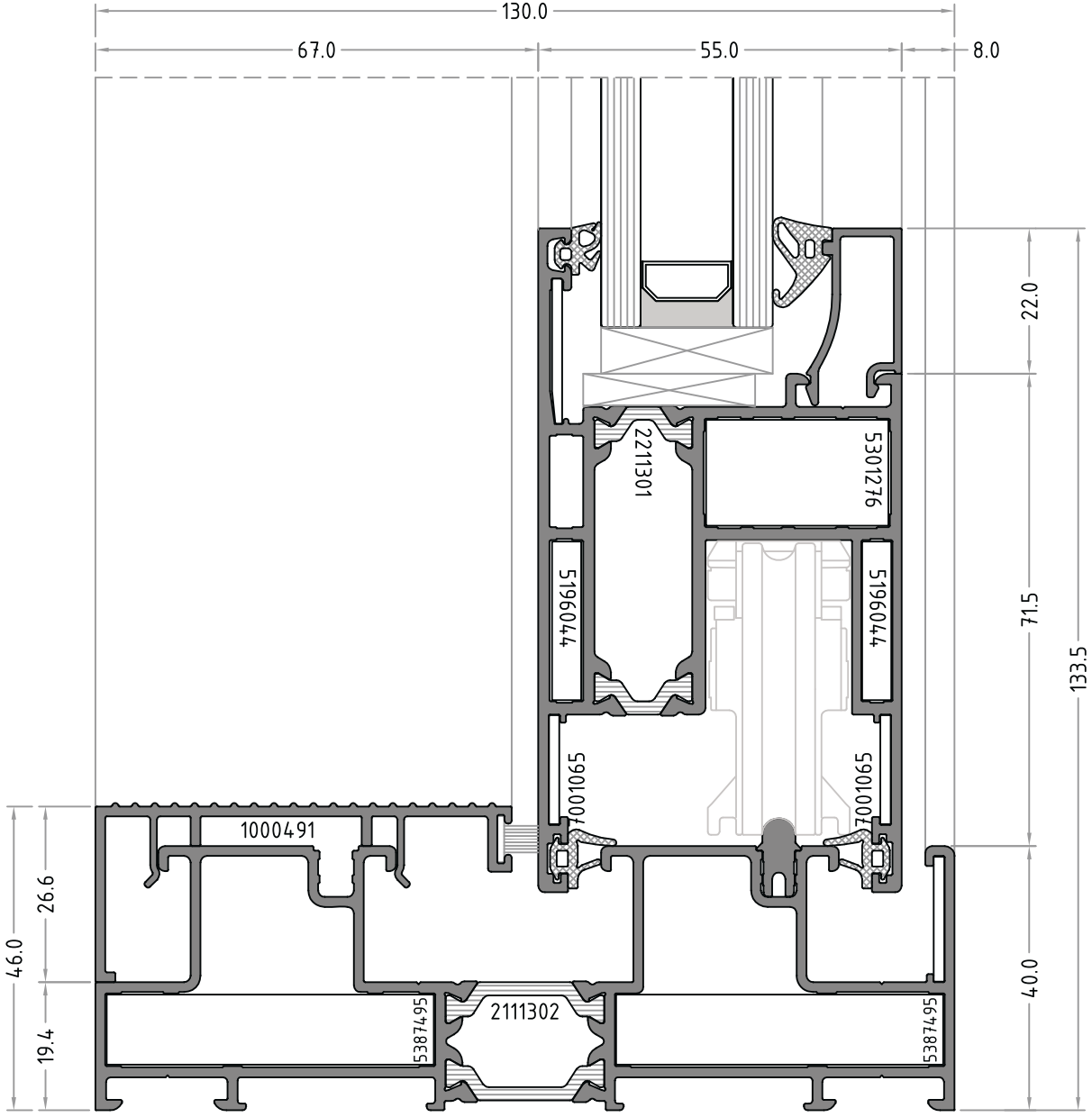
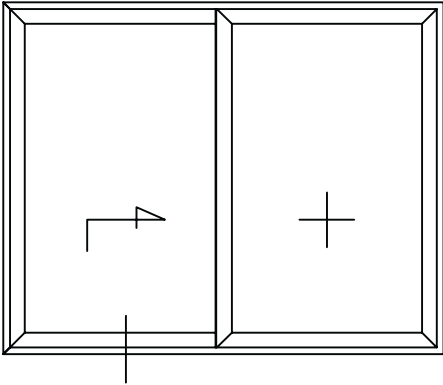

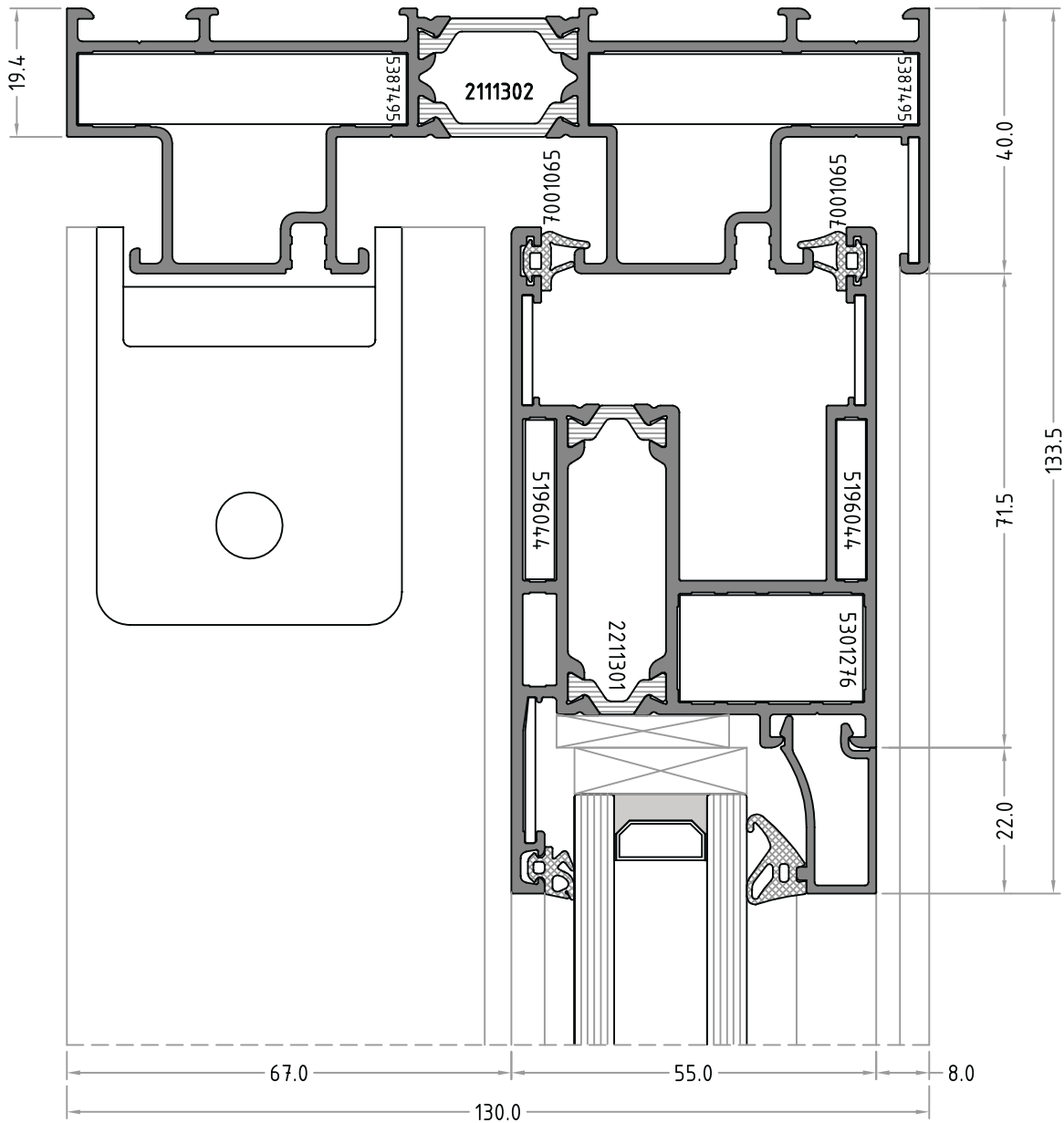
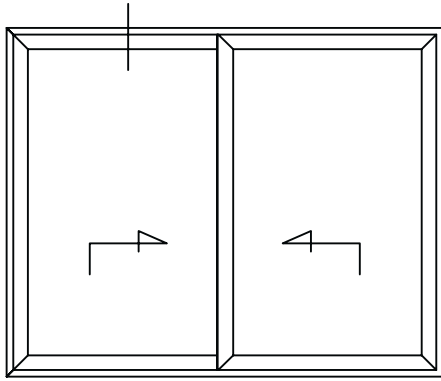



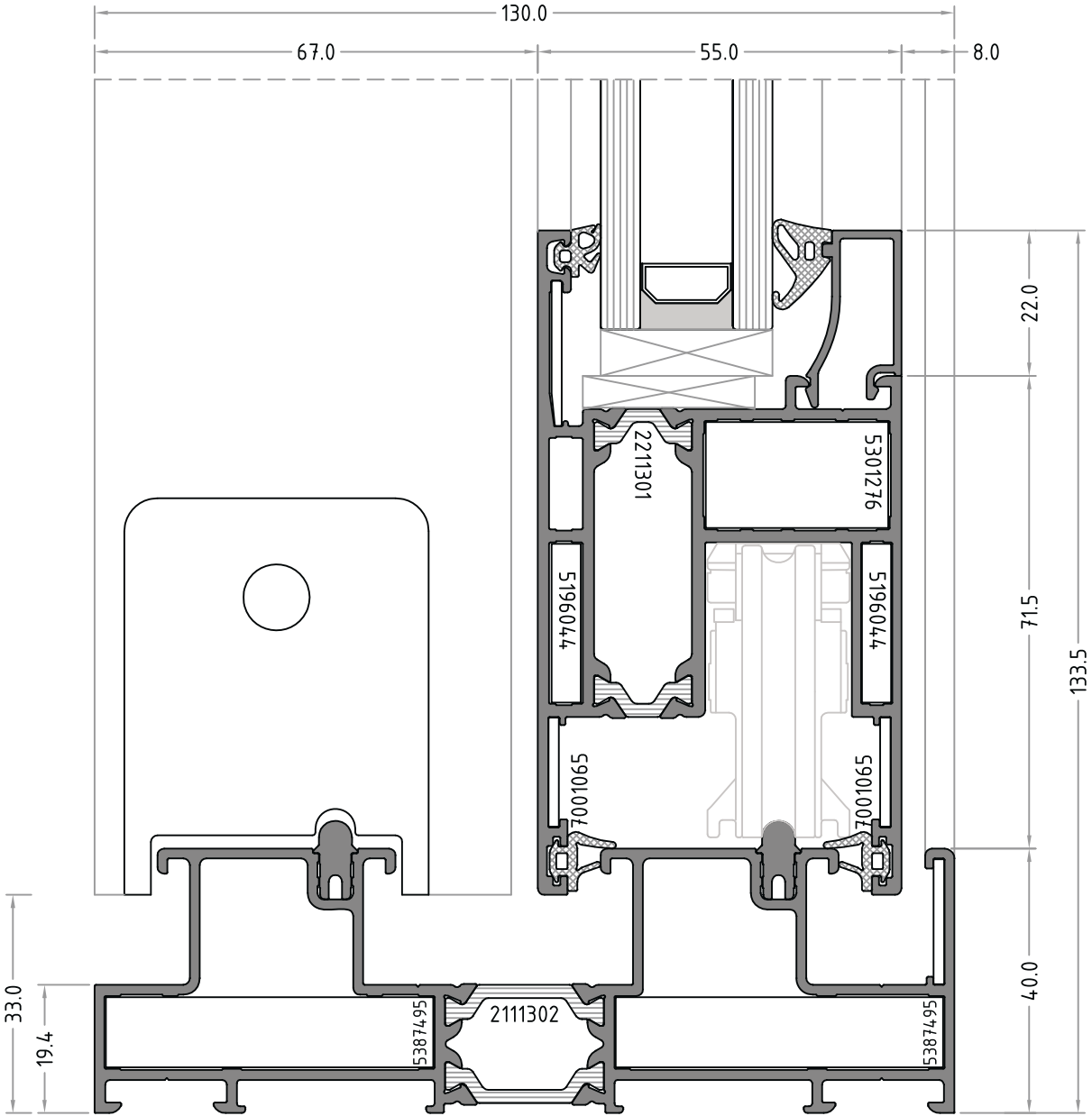
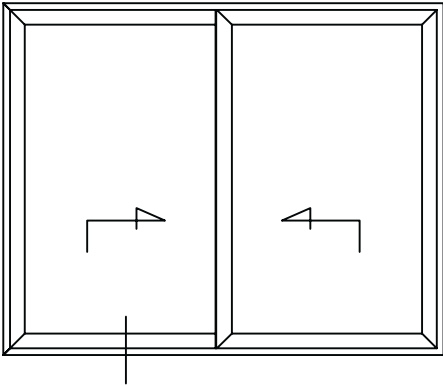

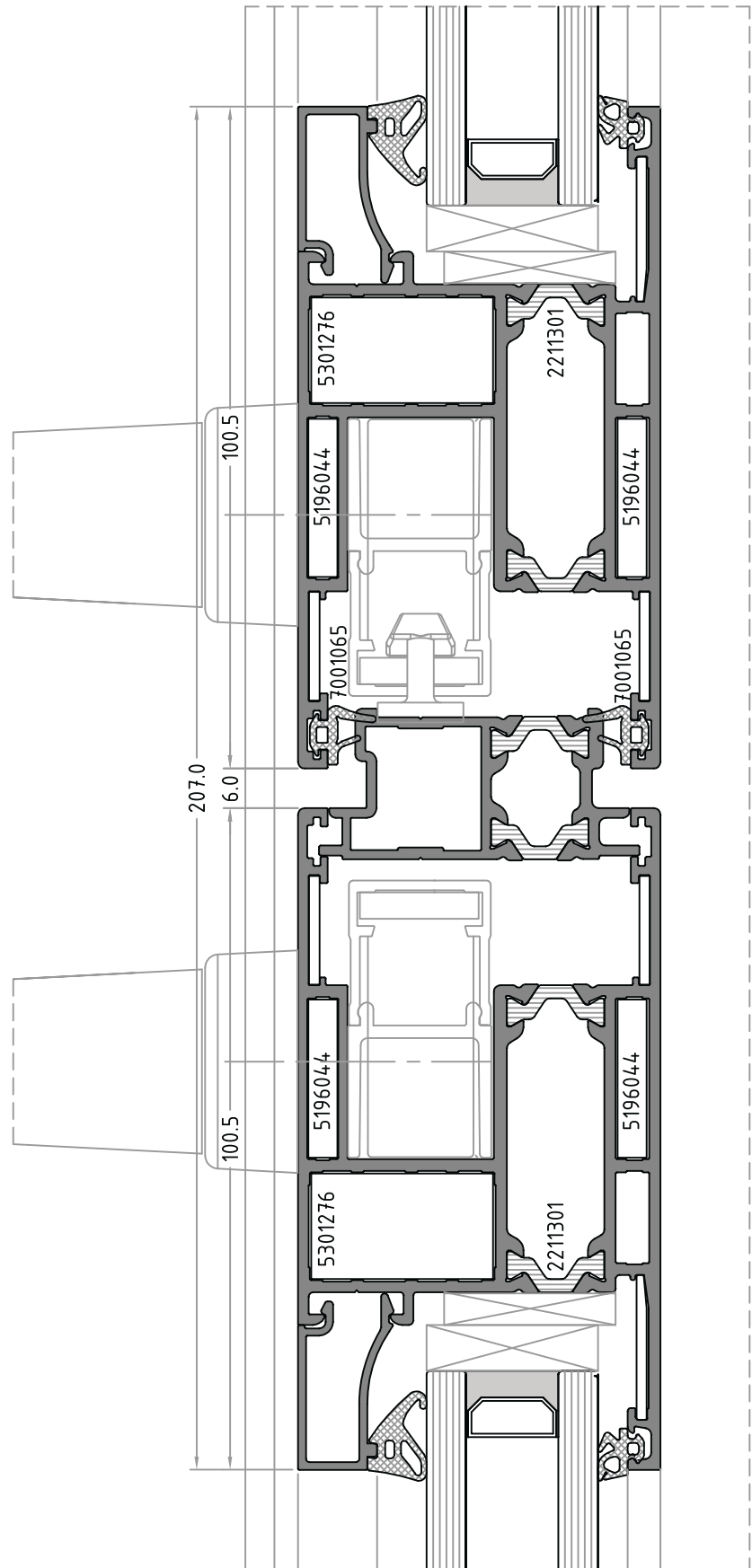
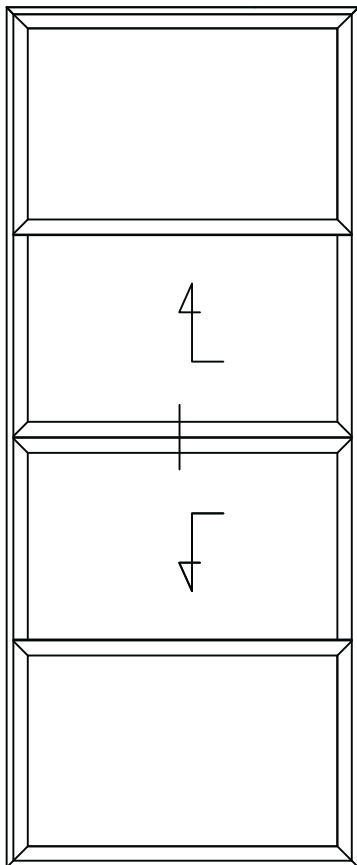
ASOU 130 Lift & Slide System



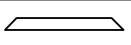
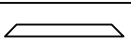
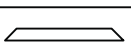
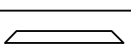
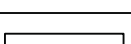
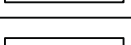
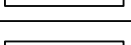
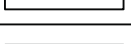
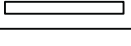
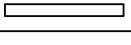
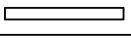

ASOU 130 Lift & Slide System

				
2111302		W	2	No.
2111302		H	2	No.
2211301		$(W / 2) + 15$	4	No.
2211301		H - 66	4	No.
1000493		H - 66	2	No.
1000492		H - 39	1	No.
1000492		$(W / 2) - 109$	1	No.
1000491		$(W / 2) - 109$	1	No.
1000213 *		$(W / 2) - 142$	4	No.
1000213 *		H - 267	4	No.
1000461		W - 80	2	No.
Gaskets & Sealing		لاستیک و کرکی		
7001001	$(2 \times W) + (4 \times H)$			m.
7001002 *	$(2 \times W) + (4 \times H)$			m.
7001043	$2 \times H$			m.
7001058	$2 \times H$			m.
7001065	$(4 \times W) + (4 \times H)$			m.
7906807	$(W) + (5 \times H)$			m.
System Accessories		یراق آلات سیستم		
5387495	8			Pcs.
5301276	8			Pcs.
5196044	16			Pcs.
4901002	16			Pcs.
7501011	8			Pcs.
7501020	4			Pcs.
7501017	1			Set.

* Depend on Glazing Thickness.

* بر اساس ضخامت شیشه

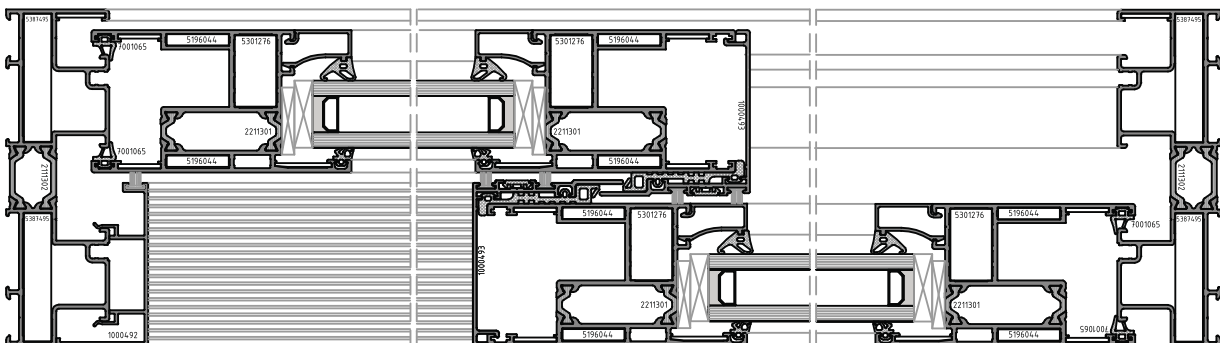
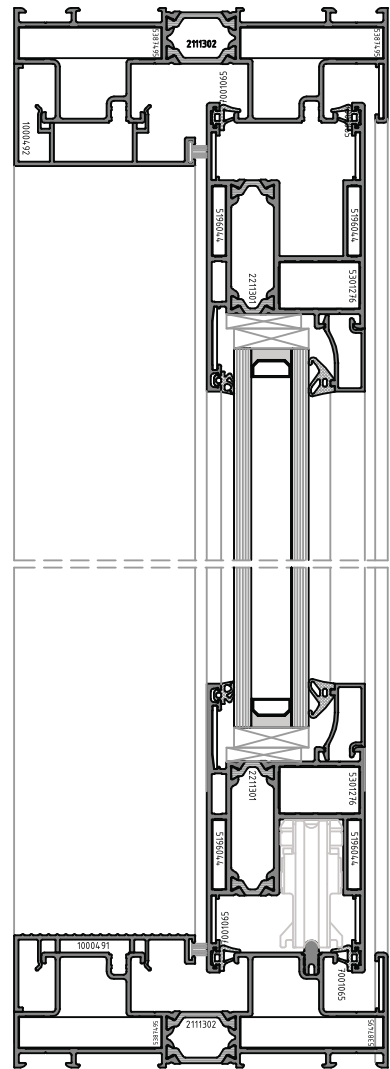
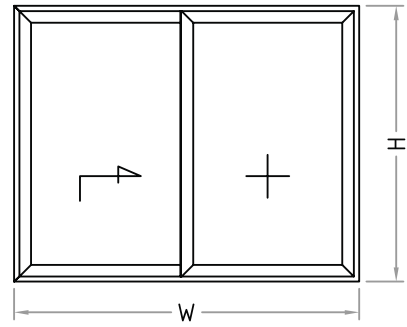

سیستم لیفت اسلاید آسو ۱۳۰



2111302		W	2	No.
2111302		H	2	No.
2211301		$(W / 3) + 42$	6	No.
2211301		H - 66	6	No.
1000493		H - 66	4	No.
1000492		H - 39	2	No.
1000492		$(W / 3) - 82$	2	No.
1000491		$(W / 3) - 82$	2	No.
1000213 *		$(W / 3) - 115$	6	No.
1000213 *		H - 267	6	No.
1000461		W - 80	2	No.

لاستیک و کرکی

7001001	$(2 \times W) + (6 \times H)$	m.
7001002 *	$(2 \times W) + (6 \times H)$	m.
7001043	4 x H	m.
7001058	4 x H	m.
7001065	$(4 \times W) + (6 \times H)$	m.
7906807	$((W / 3) \times 4) + (8 \times H)$	m.

براق آلات سیستم

5387495	8	Pcs.
5301276	12	Pcs.
5196044	24	Pcs.
4901002	24	Pcs.
7501011	12	Pcs.
7501020	4	Pcs.
7501017	2	Set.





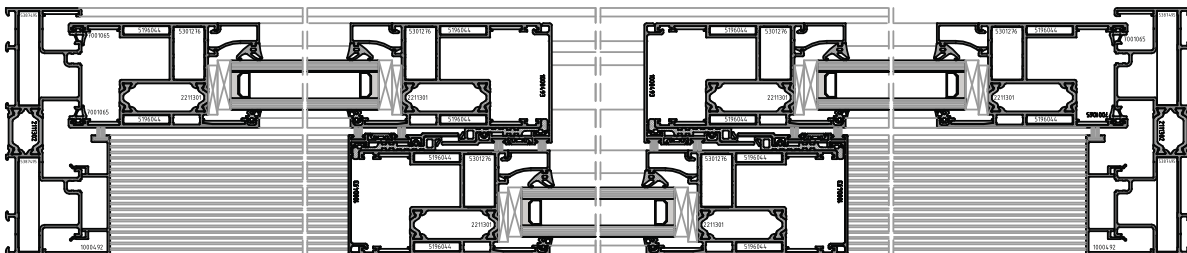
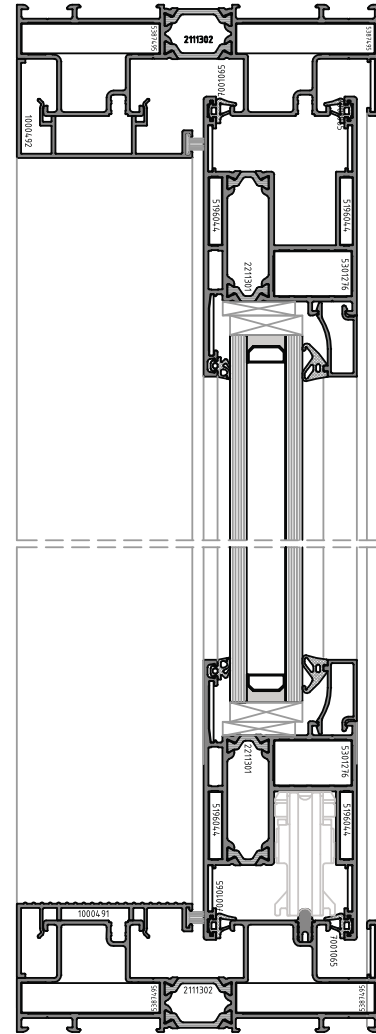
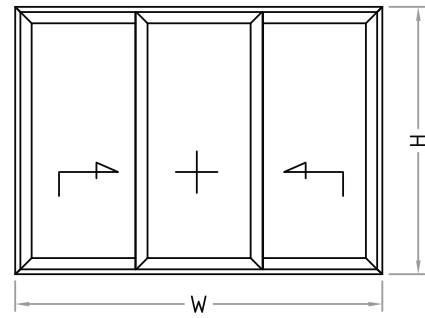

* Depend on Glazing Thickness.

* بر اساس ضخامت شیشه

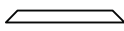
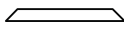
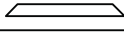
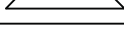
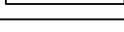
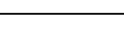
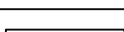
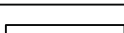

ASOU 130 Dual Rail

ASOU 130 Lift & Slide System

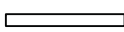
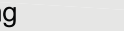
					
2111302		W	2	No.	
2111302		H	2	No.	
2211301		$(W / 4) + 30$	8	No.	
2211301		H - 66	8	No.	
2611301		H - 80	1	No.	
1000493		H - 66	4	No.	
1000492		$(W / 2) - 137$	1	No.	
1000491		$(W / 2) - 137$	1	No.	
1000213 *		$(W / 4) - 127$	8	No.	
1000213 *		H - 267	8	No.	
1000461		W - 80	2	No.	
Gaskets & Sealing لاستیک و کرکی					
7001001	$(2 \times W) + (8 \times H)$			m.	
7001002 *	$(2 \times W) + (8 \times H)$			m.	
7001043	4 x H			m.	
7001058	4 x H			m.	
7001065	$(4 \times W) + (6 \times H)$			m.	
7906807	W + (8 x H)			m.	
System Accessories یراق آلات سیستم					
5387495	8			Pcs.	
5301276	16			Pcs.	
5196044	32			Pcs.	
4901002	32			Pcs.	
7501011	16			Pcs.	
7501020	4			Pcs.	
7501017	2			Set.	

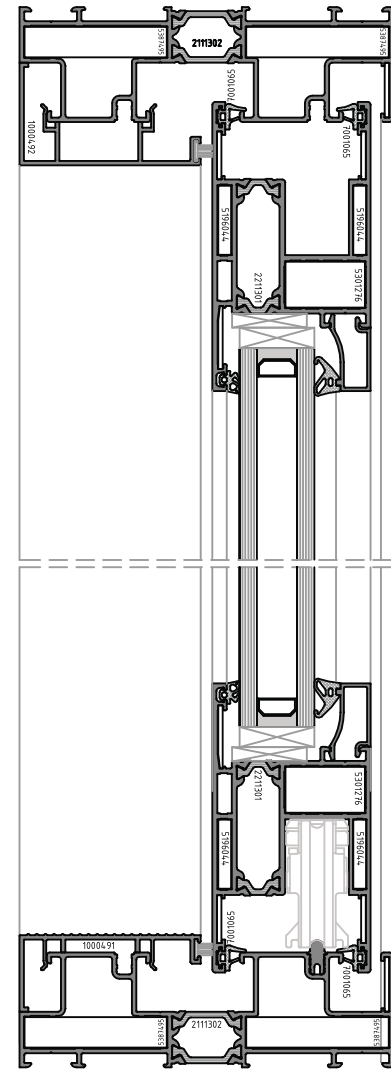
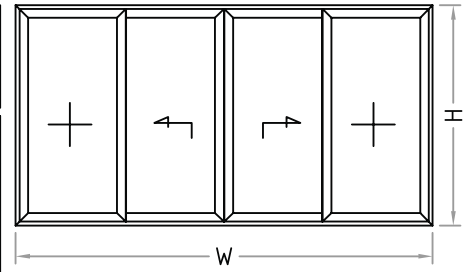

* Depend on Glazing Thickness.

* بر اساس ضخامت شیشه

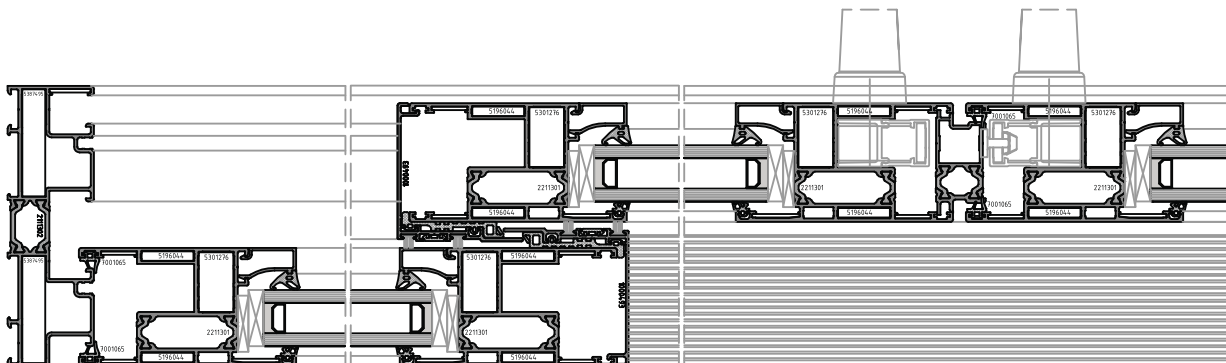

سیستم لیفت اسلاید آسو ۱۳۰

0000000				
2111302		W	2	No.
2111302		H	2	No.
2211301		$(W / 4) + 30$	8	No.
2211301		H - 66	8	No.
2611301		H - 80	1	No.
1000493		H - 66	4	No.
1000492		$(W / 4) - 94$	2	No.
1000492		H - 39	2	No.
1000491		$(W / 4) - 94$	2	No.
1000213 *		$(W / 4) - 127$	8	No.
1000213 *		H - 267	8	No.
1000461		W - 80	2	No.
Gaskets & Sealing		لاستیک و کرکی		
7001001	$(2 \times W) + (8 \times H)$	m.		
7001002 *	$(2 \times W) + (8 \times H)$	m.		
7001043	4 x H	m.		
7001058	4 x H	m.		
7001065	$(4 \times W) + (6 \times H)$	m.		
7906807	$W + (10 \times H)$	m.		
System Accessories		یراق آلات سیستم		
5387495	8	Pcs.		
5301276	16	Pcs.		
5196044	32	Pcs.		
4901002	32	Pcs.		
7501011	16	Pcs.		
7501020	4	Pcs.		
7501017	2	Set.		

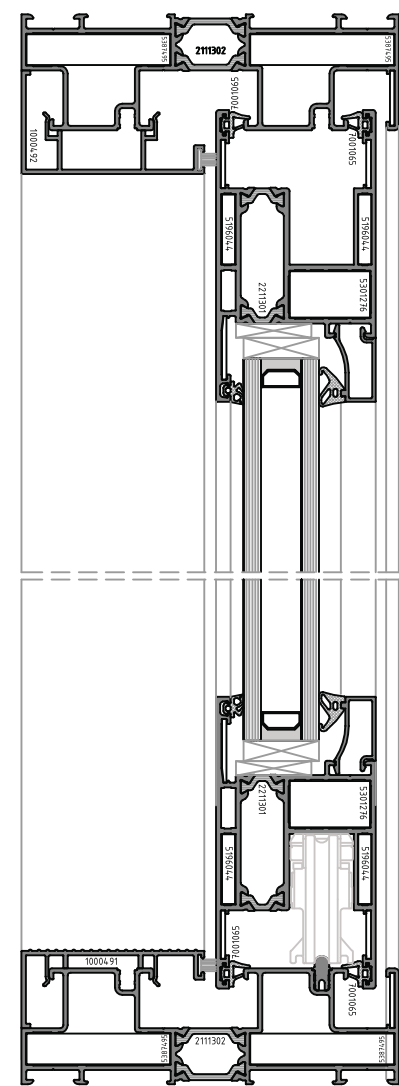
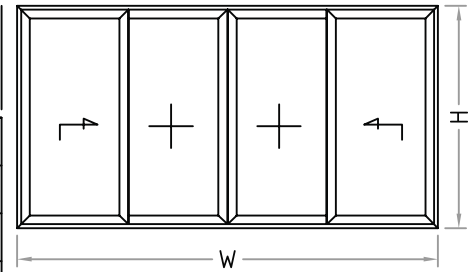

* Depend on Glazing Thickness.

* بر اساس ضخامت شیشه

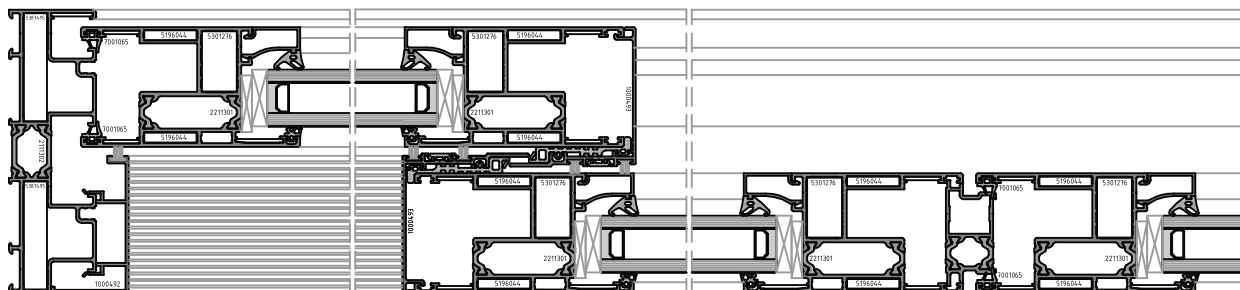

ASOU 130 Dual Rail

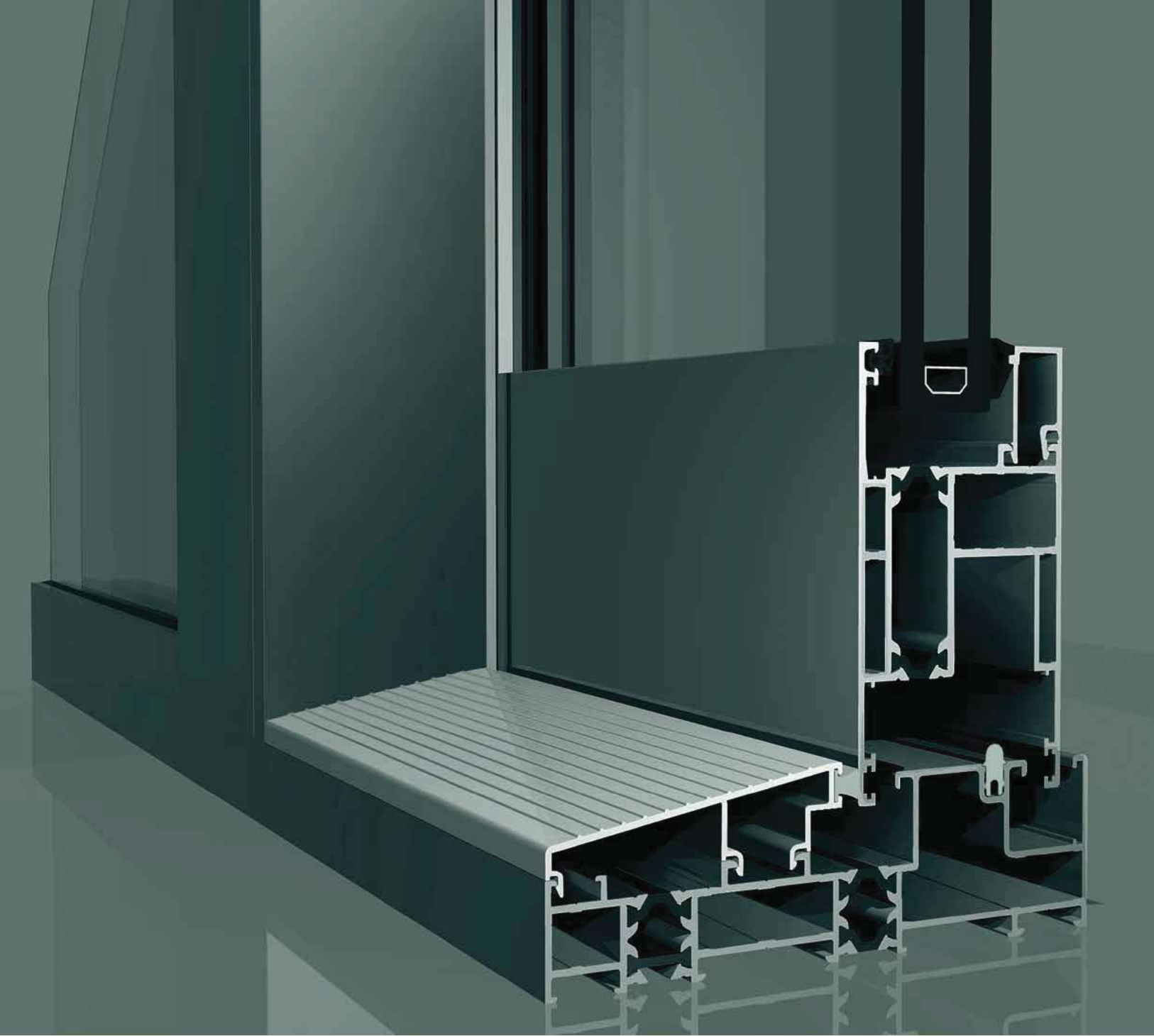

INOPEX
Innovated Profile Extrusion

ASOU 130

MONORAIL LIFT & SLIDE SYSTEM

آسو 130

سیستم لیفت اسلاید مونوریل

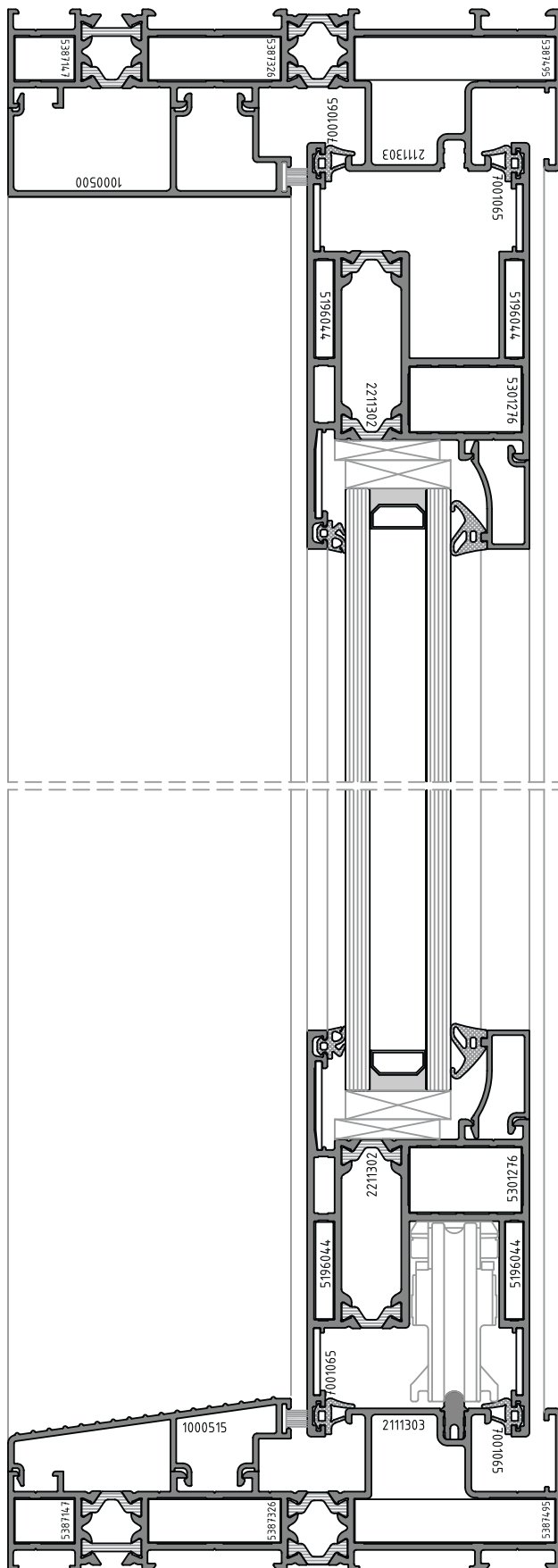

پنجره (در) لیفت اسلاید با توجه به ابعاد بزرگ قابل ساخت آنها معمولاً برای ورودی بالکن‌ها و یا محل‌هایی که منظر مهم است ساخته می‌شوند و به همین دلیل با نام درهای بالکنی نیز شناخته می‌شوند. در این پنجره‌ها ترکیب کلی شامل یک یا چند لنگه بازشو و یک یا چند لنگه ثابت می‌باشند. سیستم مونو ریل آسو ۱۳۰ به دلیل اینکه حداکثر دید ممکن را برای قسمت‌های ثابت و همچنین در قسمت بازشو حداقل ارتفاع و پاگیری ممکن را فراهم می‌نماید طراحی شده است. علاوه بر این امکان داشتن بازشوی لولایی در قسمت‌های ثابت از مزایای این سیستم می‌باشد.

تفاوت عمده سیستم دو ریل و مونو ریل در قرینگی ظاهری لنگه‌ها می‌باشد و از نظر عملکردی متفاوت نیستند. در این سیستم یراق الات استاندارد ۳۰۰ و ۴۰۰ کیلویی برای هر لنگه قابل نصب می‌باشند.

Lift & slide windows (doors) are usually used as balcony entrance or in buildings that landscape views are important so they called as balcony doors as well. General combination of these windows are one or more moveable sashes and one or more fixed sashes. ASOU130 monorail system designed to give maximum view in fixed sashes and low threshold on moveable sashes. In addition the hinged sashes can be used in fixed sashes which is one of advantage of monorail systems.

Difference between ASOU130 dual rail and ASOU130 monorail is symmetrical view in fixed and openable sashes and there is no changes in functionality.

The system has the capability of using 300kg and 400kg standard accessories.

ASOU 130 Lift & Slide System

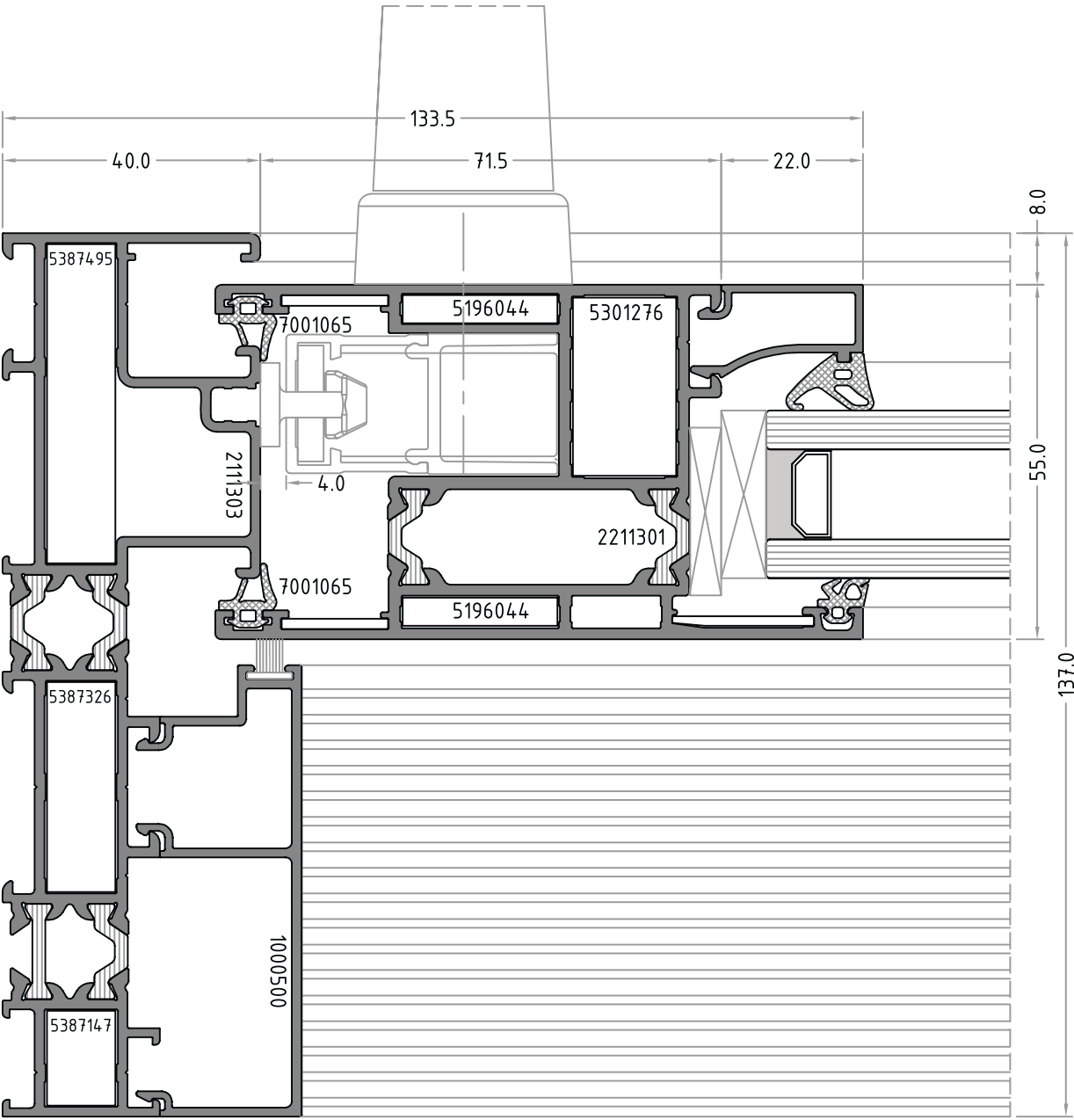
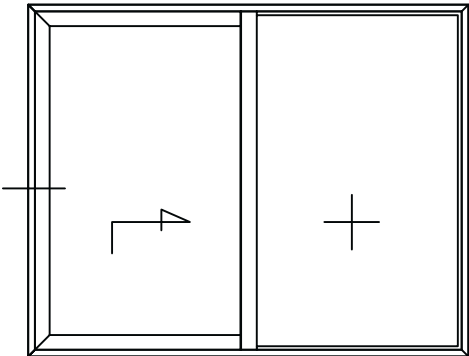

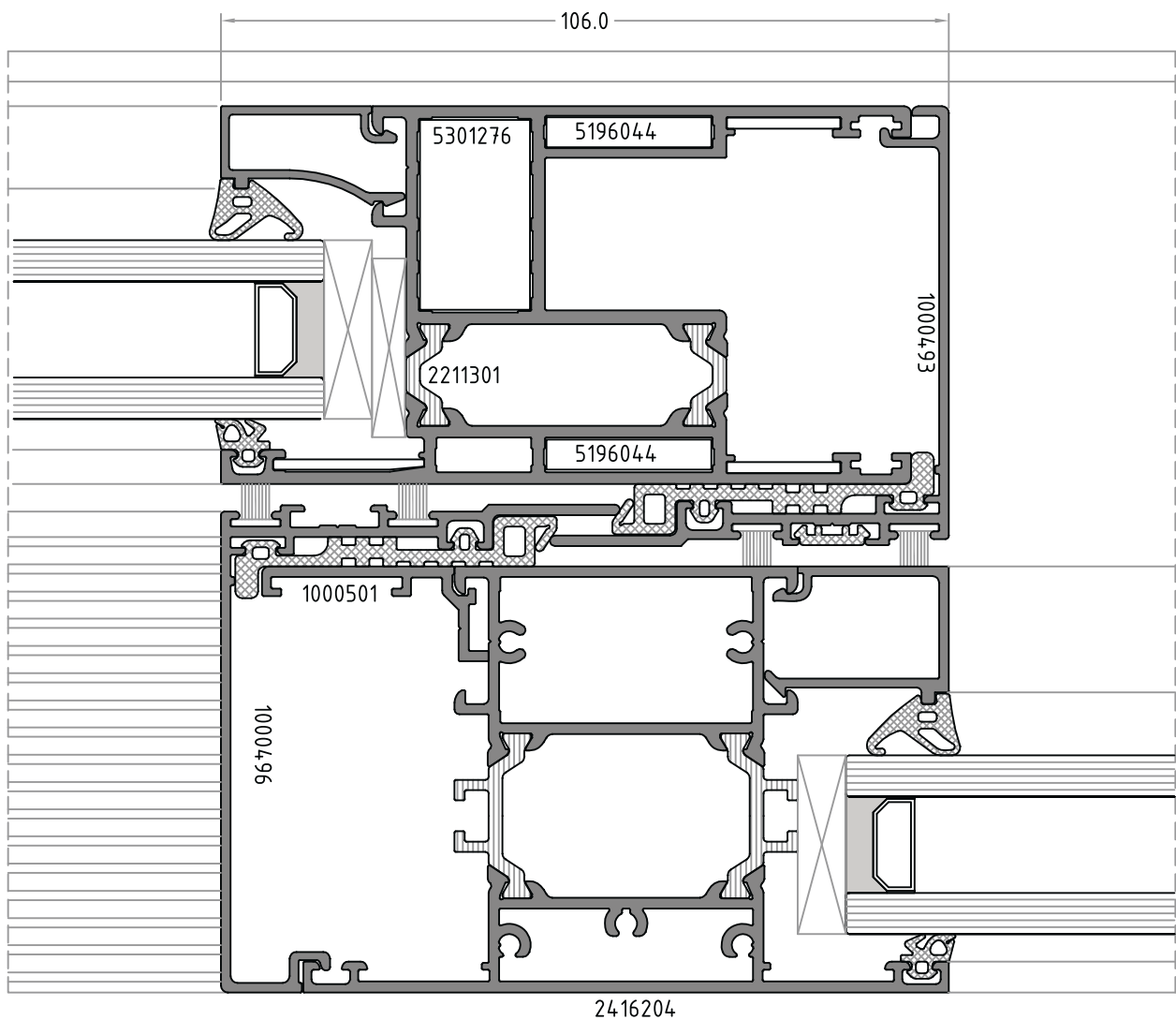
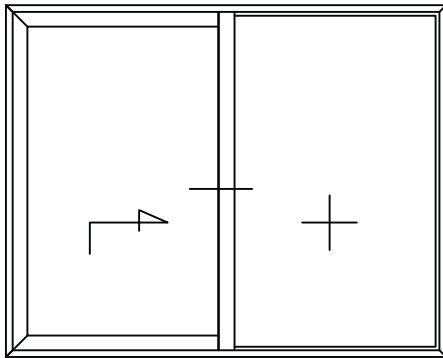

ASOU 130 Lift & Slide System

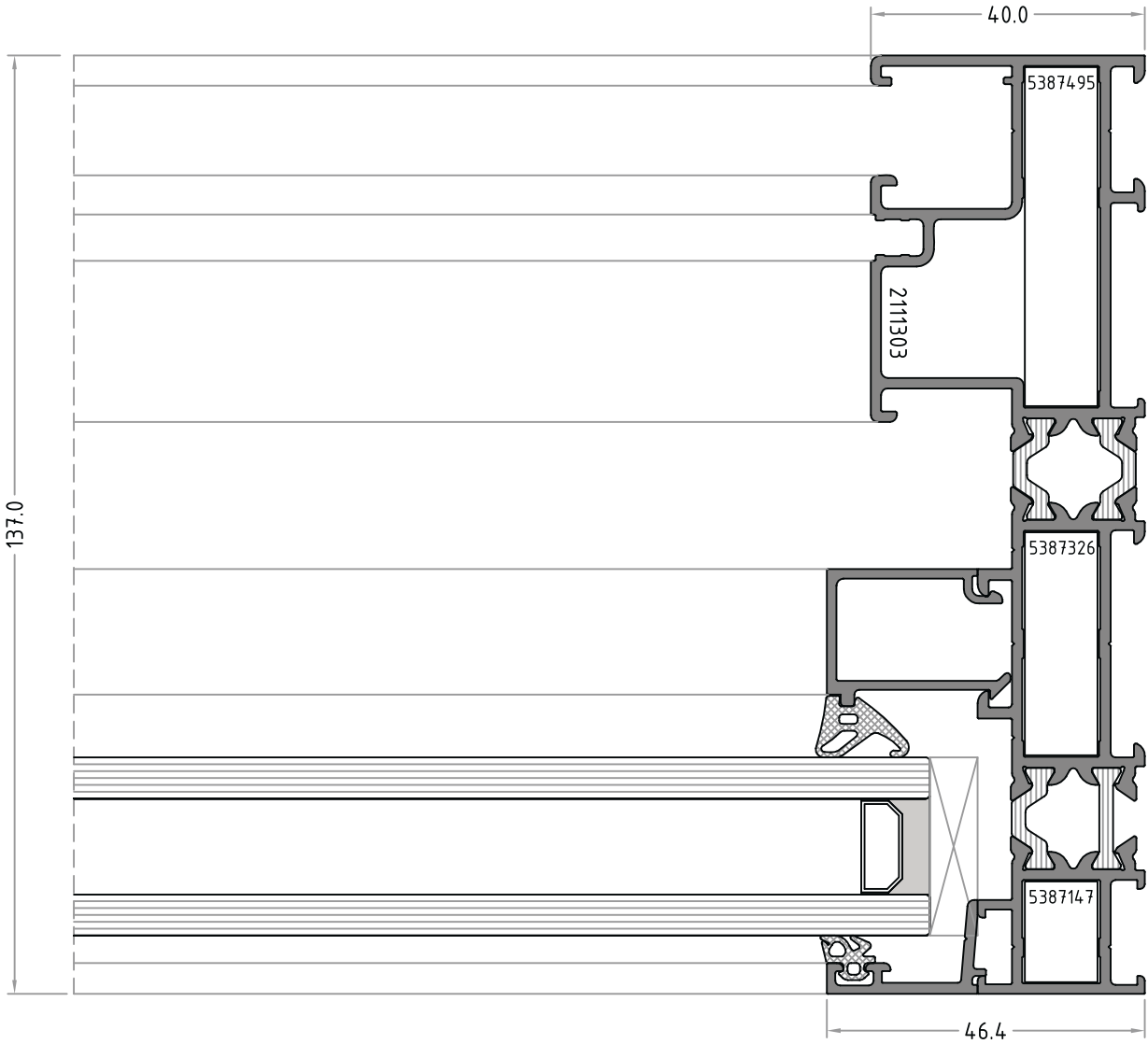
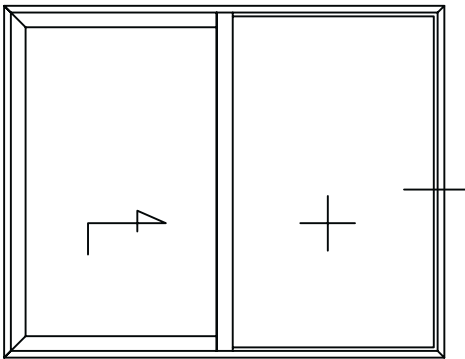

سیستم لیفت اسلاید آسو ۱۳۰

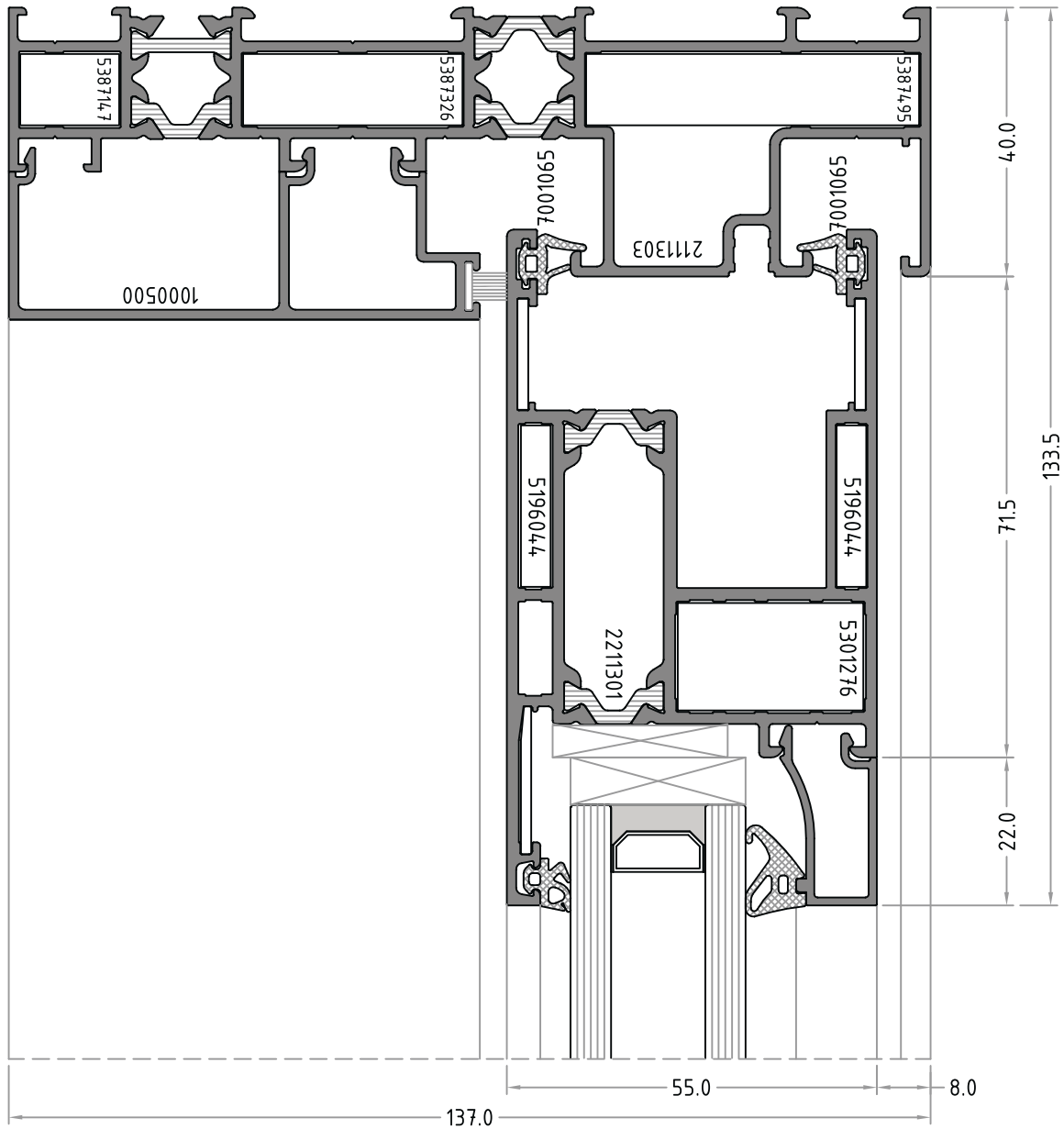
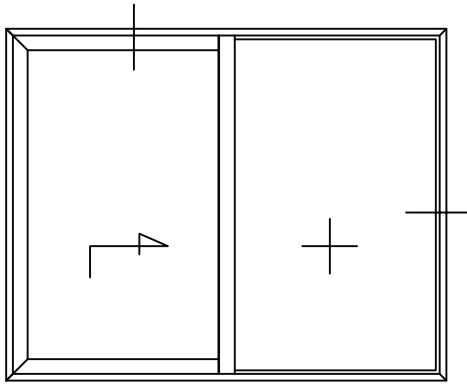

ASOU 130 Monorail

ASOU 130 Lift & Slide System

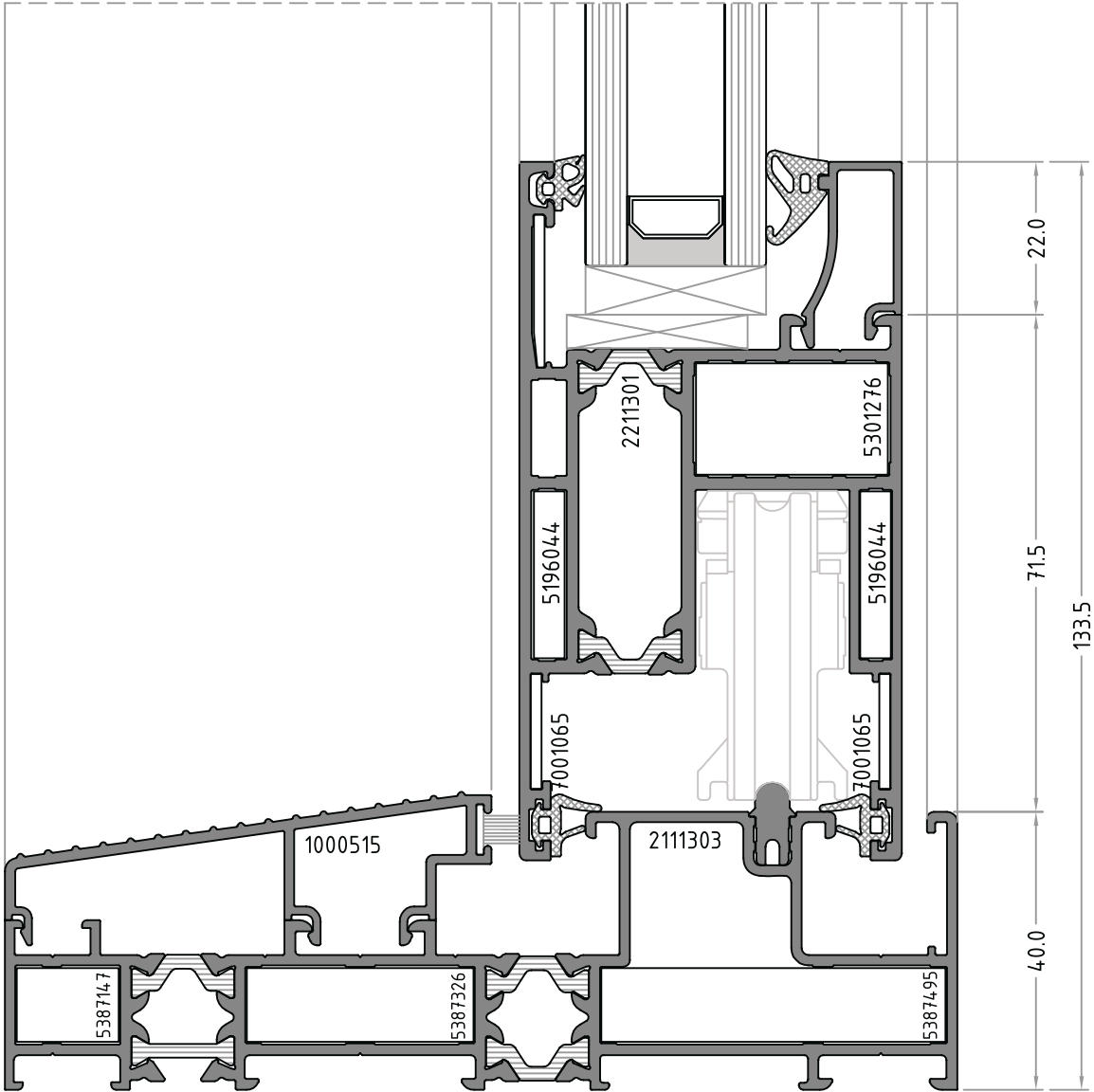
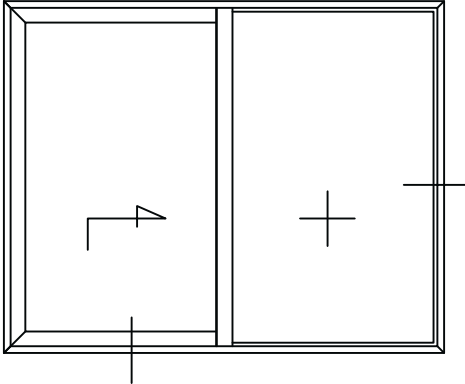

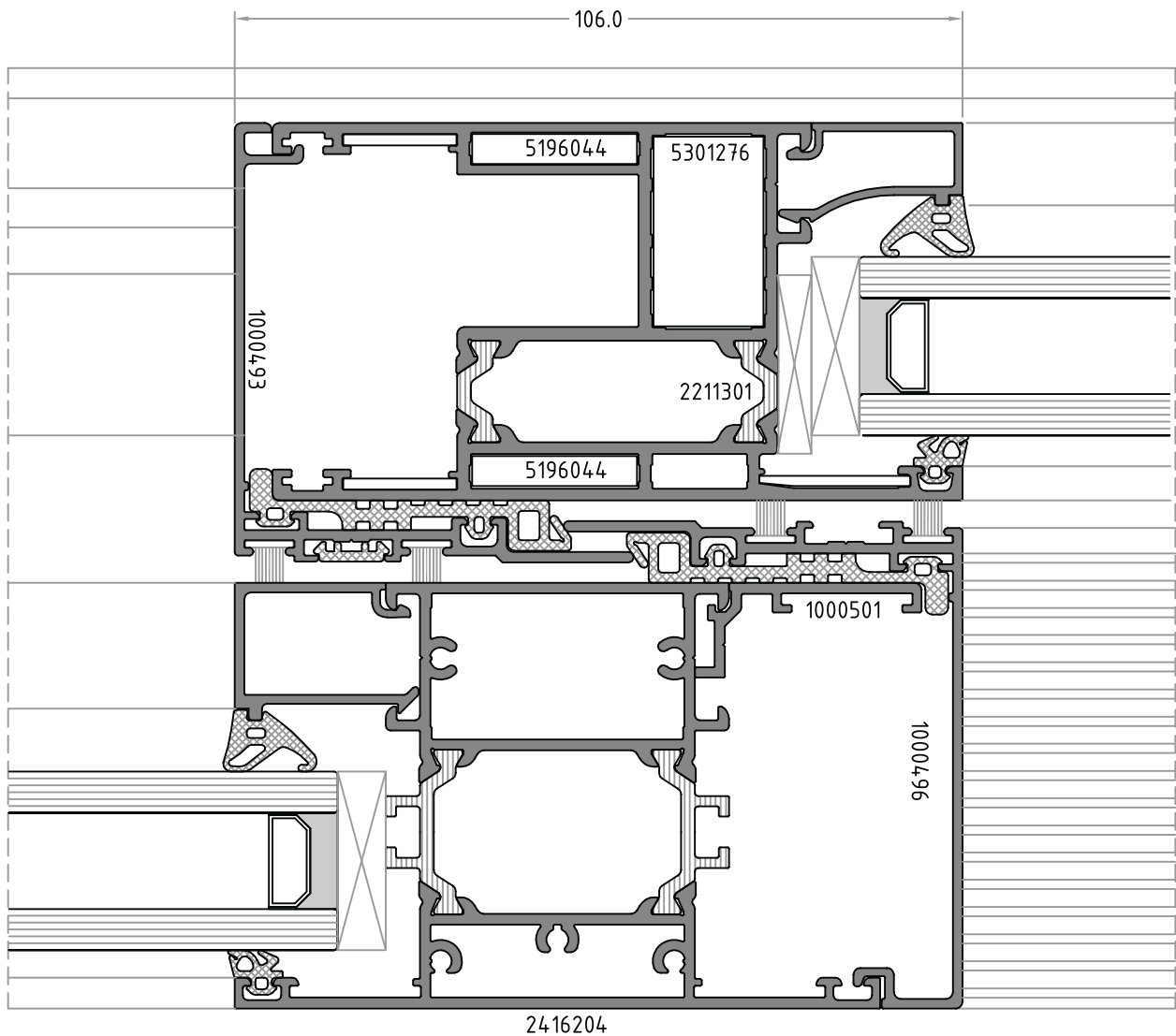
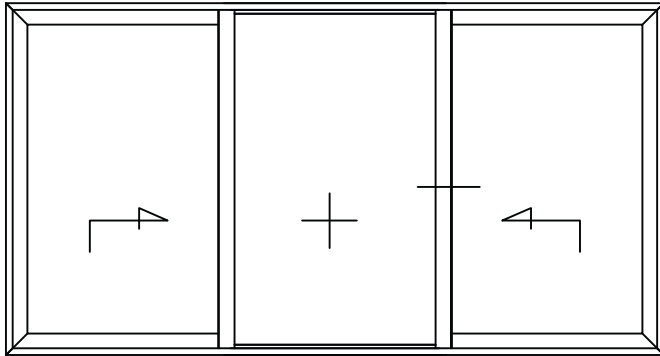



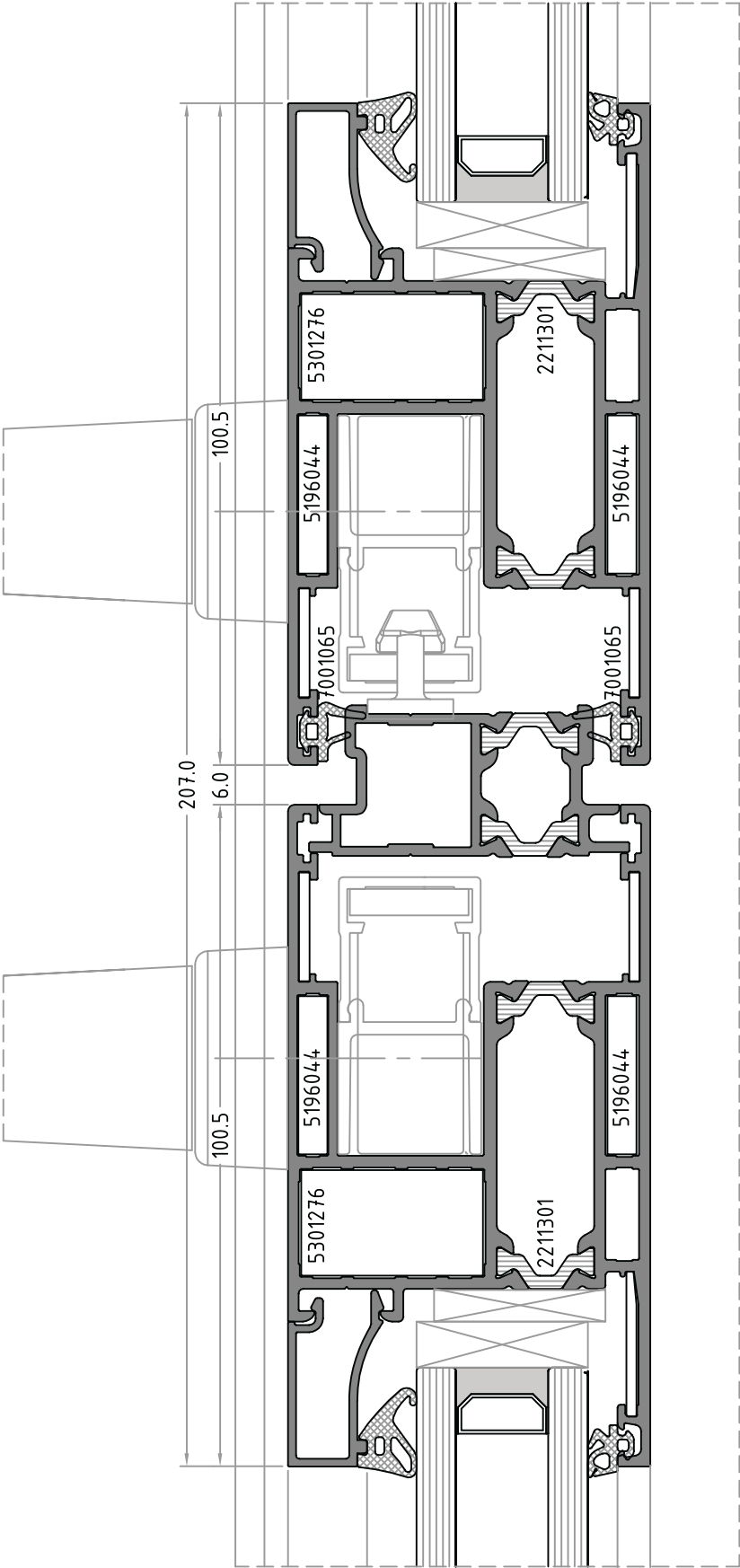
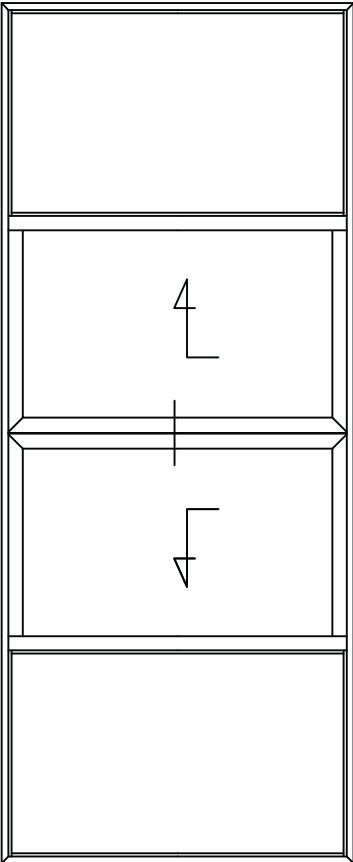

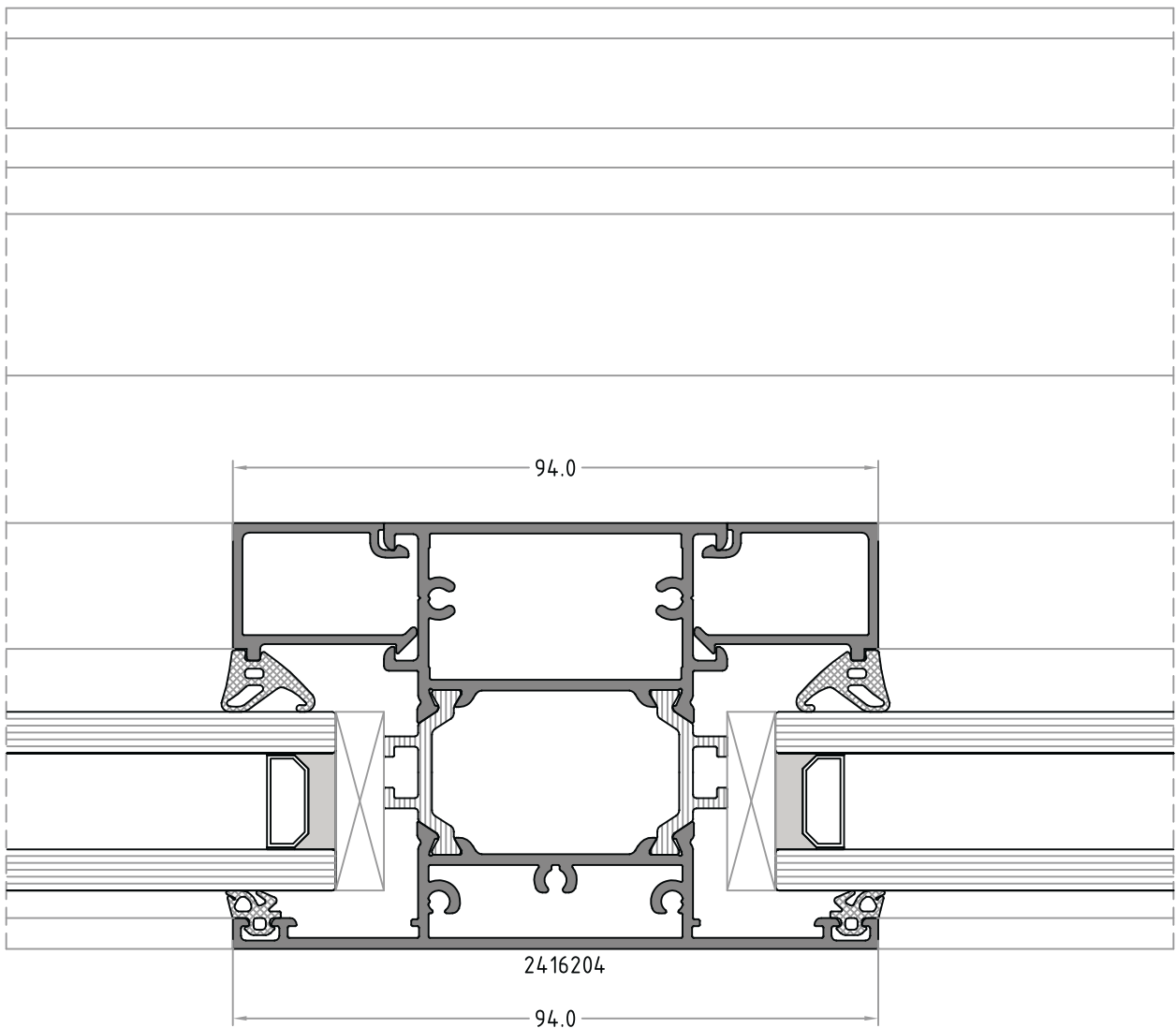
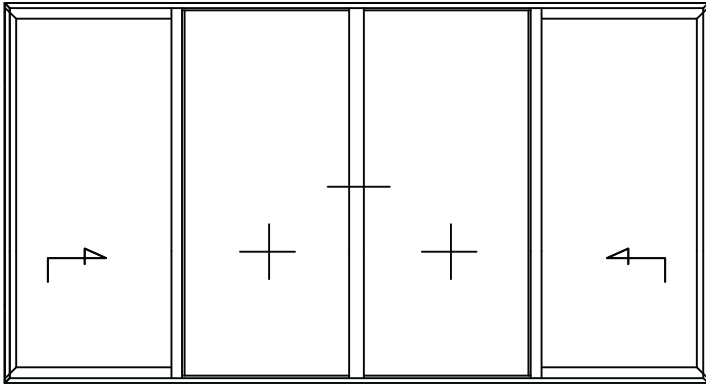







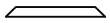
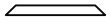

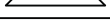
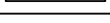
ASOU 130 Lift & Slide System

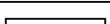

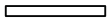
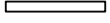
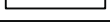
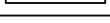

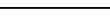
ASOU 130 Lift & Slide System



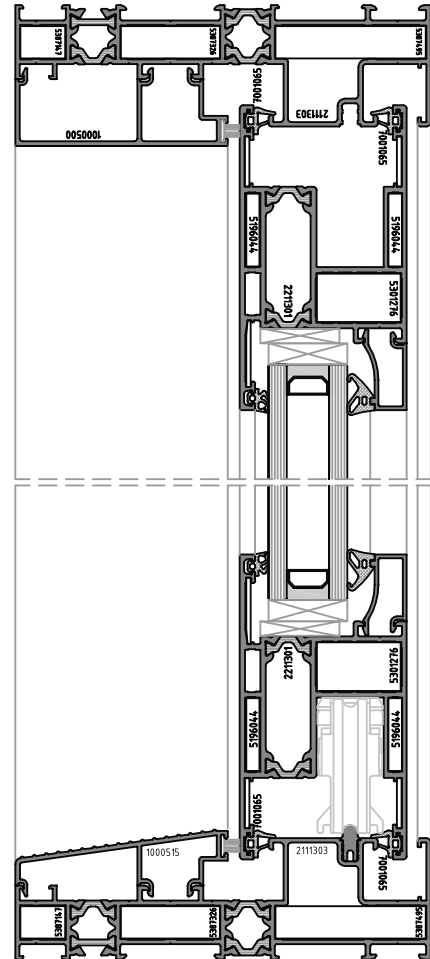
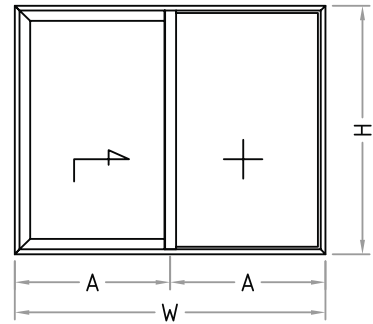



				
2111303		W	2	No.
2111303		H	2	No.
2211301		$(W / 2) + 14$	2	No.
2211301		H - 66	2	No.
2416204		H - 49	1	No.
1000501		H - 49	1	No.
1000493		H - 66	1	No.
1000496		H - 49	1	No.
1000500		H - 49	1	No.
1000500		$(W / 2) - 100$	1	No.
1000515		$(W / 2) - 100$	1	No.
1000499		H - 93	1	No.
1000499		$(W / 2) - 77$	2	No.
1000213 *		$(W / 2) - 143$	2	No.
1000213 *		H - 267	2	No.
1000405 *		$(W / 2) - 55$	2	No.
1000405 *		H - 93	2	No.
1000461		W - 80	1	No.
Gaskets & Sealing		لاستیک و کرکی		
7001001	$(2 \times W) + (4 \times H)$			m.
7001005 *	$(2 \times W) + (4 \times H)$			m.
7001043	$2 \times H$			m.
7001058	$2 \times H$			m.
7001065	$(2 \times W) + (2 \times H)$			m.
7906807	$(W) + (4 \times H)$			m.
System Accessories		پراق آلات سیستم		
5387495	4			Pcs.
5387326	4			Pcs.
5387147	4			Pcs.
5301276	4			Pcs.
5196044	8			Pcs.
4901002	8			Pcs.
7501011	4			Pcs.
7501020	4			Pcs.
7501017	1			Set.

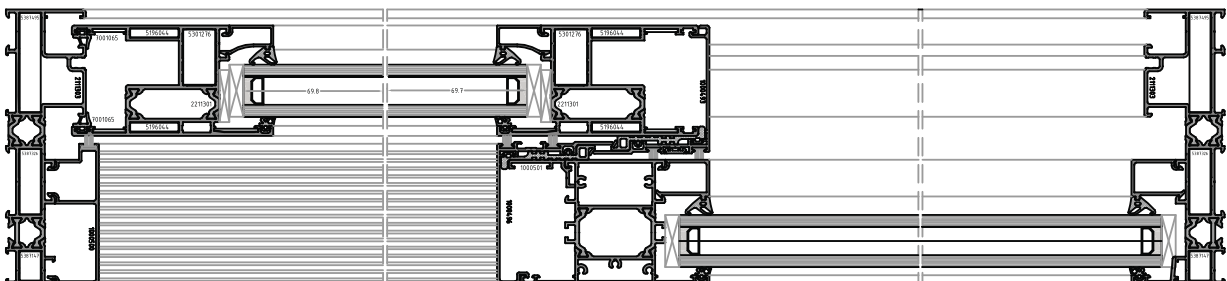

* Depend on Glazing Thickness.

* بر اساس ضخامت شیشه

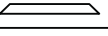
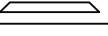
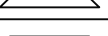
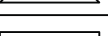
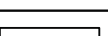
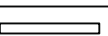
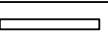
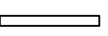
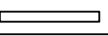
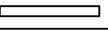
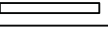
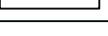
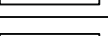
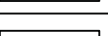
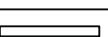

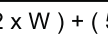
				
2111303		W	2	No.
2111303		H	2	No.
2211301		$(W / 2) + 14$	4	No.
2211301		H - 66	4	No.
2416204		H - 49	2	No.
1000501		H - 49	2	No.
1000493		H - 66	2	No.
1000496		H - 49	2	No.
1000500		H - 49	2	No.
1000500		$(W / 3) - 100$	2	No.
1000515		$(W / 3) - 100$	2	No.
1000499		$(W / 3) - 106$	2	No.
1000213 *		$(W / 3) - 143$	4	No.
1000213 *		H - 267	4	No.
1000405 *		$(W / 3) - 62$	2	No.
1000405 *		H - 93	2	No.
1000461		W - 80	1	No.
Gaskets & Sealing		لاستیک و کرکی		
7001001	$(2 \times W) + (5 \times H)$			m.
7001005 *	$(2 \times W) + (5 \times H)$			m.
7001043	$4 \times H$			m.
7001058	$4 \times H$			m.
7001065	$(2 \times W) + (4 \times H)$			m.
7906807	$((W / 3) \times 4) + (10 \times H)$			m.
System Accessories		یراق آلات سیستم		
5387495	4			Pcs.
5387326	4			Pcs.
5387147	4			Pcs.
5301276	8			Pcs.
5196044	16			Pcs.
4901002	16			Pcs.
7501011	8			Pcs.
7501020	4			Pcs.
7501017	2			Set.

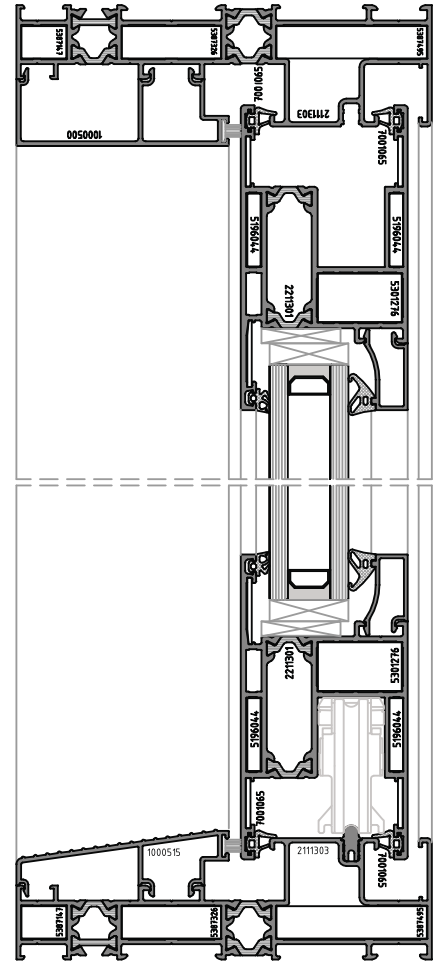
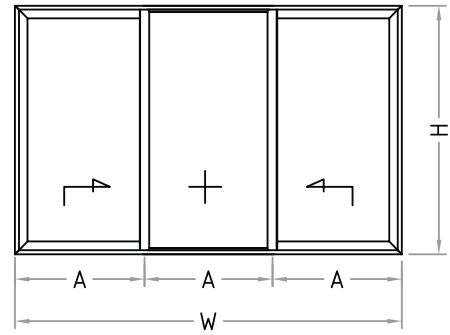





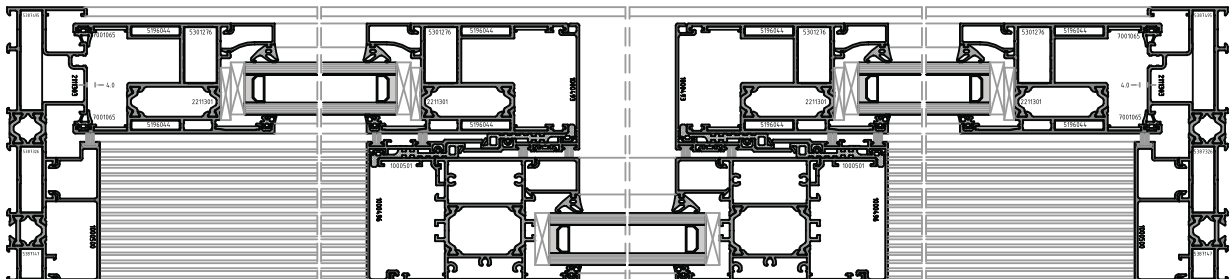





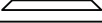
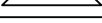
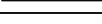
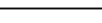
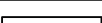

* Depend on Glazing Thickness.

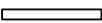
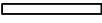
* بر اساس ضخامت شیشه

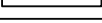

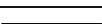
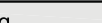
ASOU 130 Lift & Slide System

				
2111303		W	2	No.
2111303		H	2	No.
2211301		$(W / 4) + 44$	4	No.
2211301		H - 66	4	No.
2416204		H - 49	2	No.
1000501		H - 49	2	No.
1000493		H - 66	2	No.
1000496		H - 49	2	No.
1000500		$(W / 2) - 107$	1	No.
1000515		$(W / 2) - 107$	1	No.
1000499		H - 93	2	No.
1000499		$(W / 4) - 55$	4	No.
1000213 *		$(W / 4) - 113$	4	No.
1000213 *		H - 267	4	No.
1000405 *		$(W / 4) - 55$	4	No.
1000405 *		H - 93	2	No.
1000461		W - 80	1	No.
Gaskets & Sealing		لاستیک و کرکی		
7001001	$(2 \times W) + (8 \times H)$			m.
7001005 *	$(2 \times W) + (8 \times H)$			m.
7001043	$4 \times H$			m.
7001058	$4 \times H$			m.
7001065	$(2 \times W) + (2 \times H)$			m.
7906807	$(W) + (8 \times H)$			m.
System Accessories		پراق آلات سیستم		
5387495	4			Pcs.
5387326	4			Pcs.
5387147	4			Pcs.
5301276	8			Pcs.
5196044	16			Pcs.
4901002	16			Pcs.
7501011	8			Pcs.
7501020	4			Pcs.
7501017	2			Set.

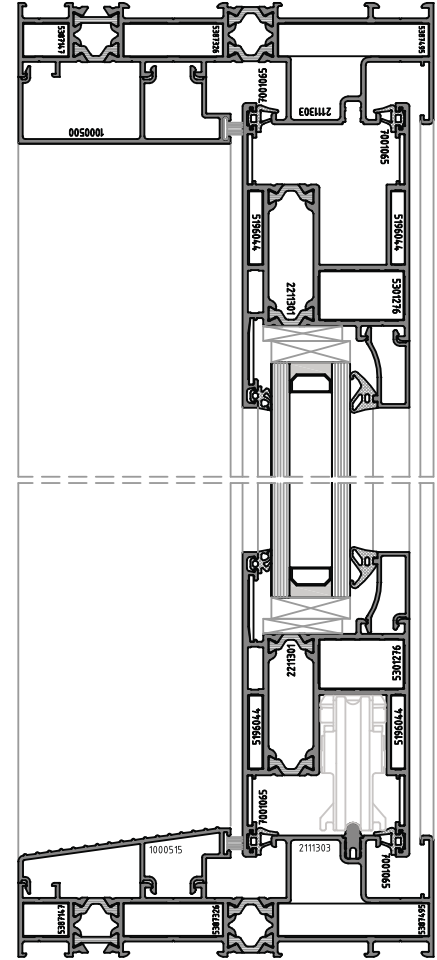
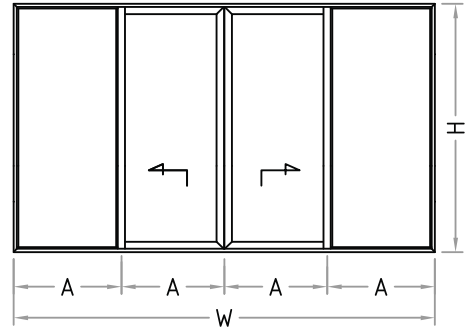





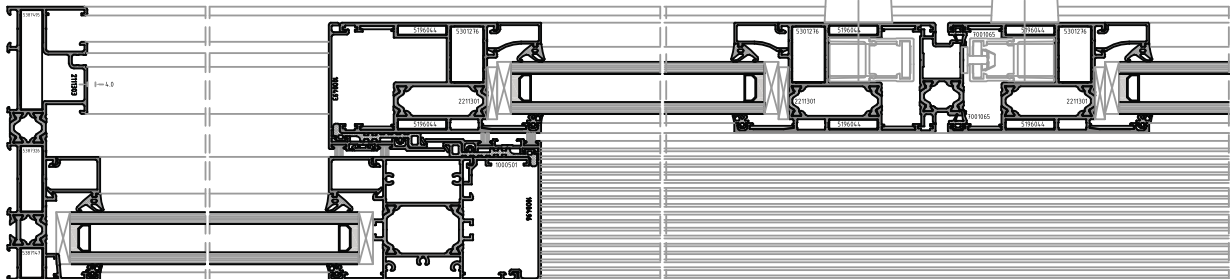







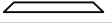

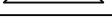
* Depend on Glazing Thickness.

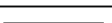
* بر اساس ضخامت شیشه

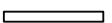
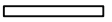
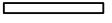
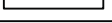
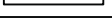

سیستم لیفت اسلاید آسو ۱۳۰

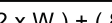
				
2111303		W	2	No.
2111303		H	2	No.
2211301		$(W / 4) + 14$	4	No.
2211301		H - 66	4	No.
2416204		H - 49	3	No.
1000501		H - 49	2	No.
1000493		H - 66	2	No.
1000496		H - 49	2	No.
1000500		H - 49	2	No.
1000500		$(W / 4) - 100$	2	No.
1000515		$(W / 4) - 100$	2	No.
1000499		$(W / 4) - 106$	4	No.
1000213 *		$(W / 4) - 143$	4	No.
1000213 *		H - 267	4	No.
1000405 *		$(W / 4) - 56$	4	No.
1000405 *		H - 93	4	No.
1000461		W - 80	1	No.
Gaskets & Sealing		لاستیک و کرکی		
7001001	$(2 \times W) + (8 \times H)$			m.
7001005 *	$(2 \times W) + (8 \times H)$			m.
7001043	$4 \times H$			m.
7001058	$4 \times H$			m.
7001065	$(2 \times W) + (4 \times H)$			m.
7906807	$(W) + (10 \times H)$			m.
System Accessories		پراق آلات سیستم		
5387495	4			Pcs.
5387326	4			Pcs.
5387147	4			Pcs.
5301276	8			Pcs.
5196044	16			Pcs.
4901002	16			Pcs.
7501011	8			Pcs.
7501020	4			Pcs.
7501017	2			Set.

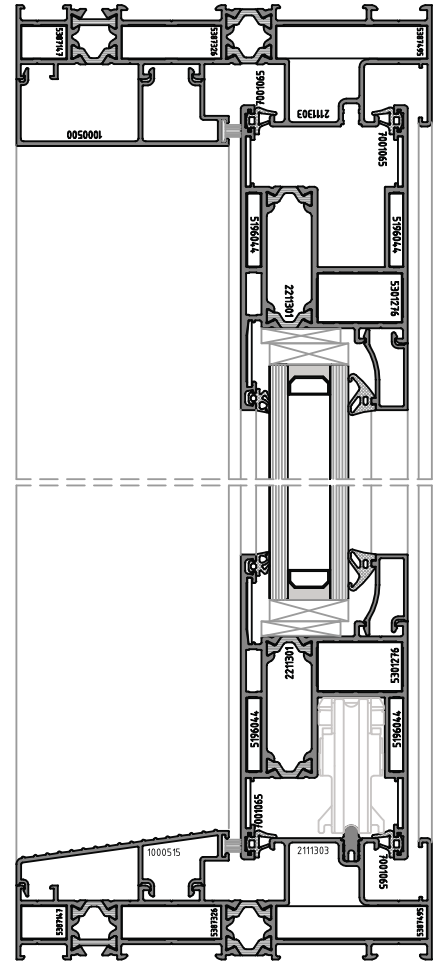
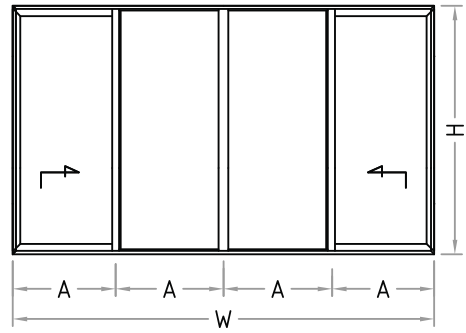

* Depend on Glazing Thickness.

* بر اساس ضخامت شیشه

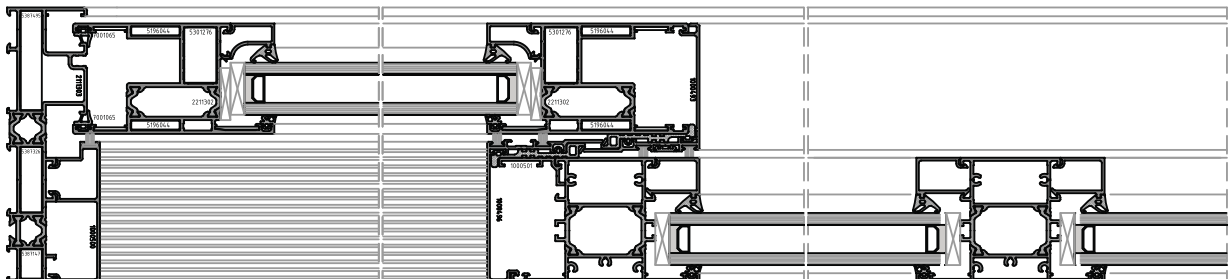

ASOU 130 Lift & Slide System

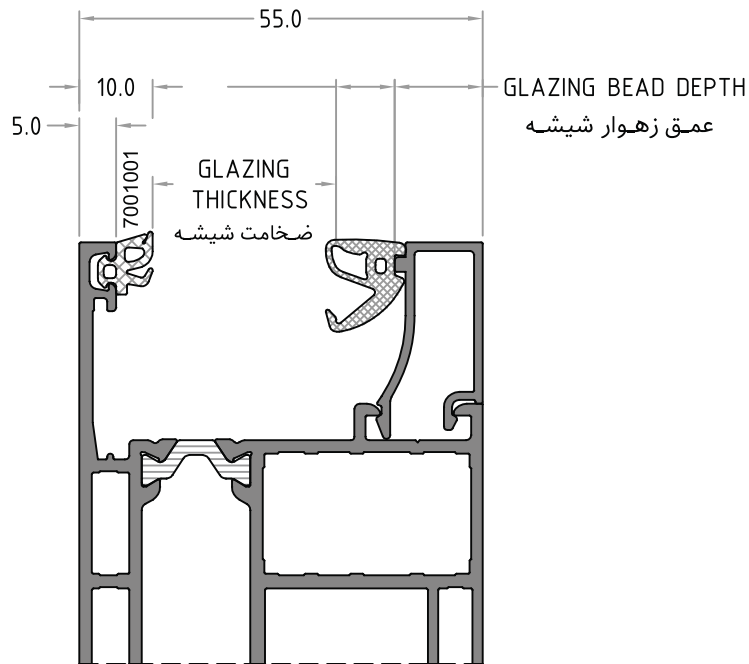

Glazing Thick.	Internal Gasket & Thick.		Glazing Bead & Depth	
ضخامت شیشه	کد و عمق لاستیک		شماره پروفیل و عمق زهوار	
6mm.	7001002	9mm.	1000193	30mm.
8mm.	7001005	7mm.	1000193	30mm.
10mm.	7001034	5mm.	1000193	30mm.
12mm.	7001002	8mm.	1000194	25mm.
14mm.	7001005	6mm.	1000194	25mm.
16mm.	7001034	4mm.	1000194	25mm.
18mm.	7001005	7mm.	1000285	20mm.
20mm.	7001062	10mm.	1000286	15mm.
22mm.	7001002	8mm.	1000286	15mm.
24mm.	7001005	6mm.	1000286	15mm.
26mm.	7001005	7mm.	1000213	12mm.
28mm.	7001034	5mm.	1000213	12mm.
30mm.	7001062	10mm.	1000334	5mm.
32mm.	7001002	8mm.	1000334	5mm.
34mm.	7001005	6mm.	1000334	5mm.
36mm.	7001034	4mm.	1000334	5mm.

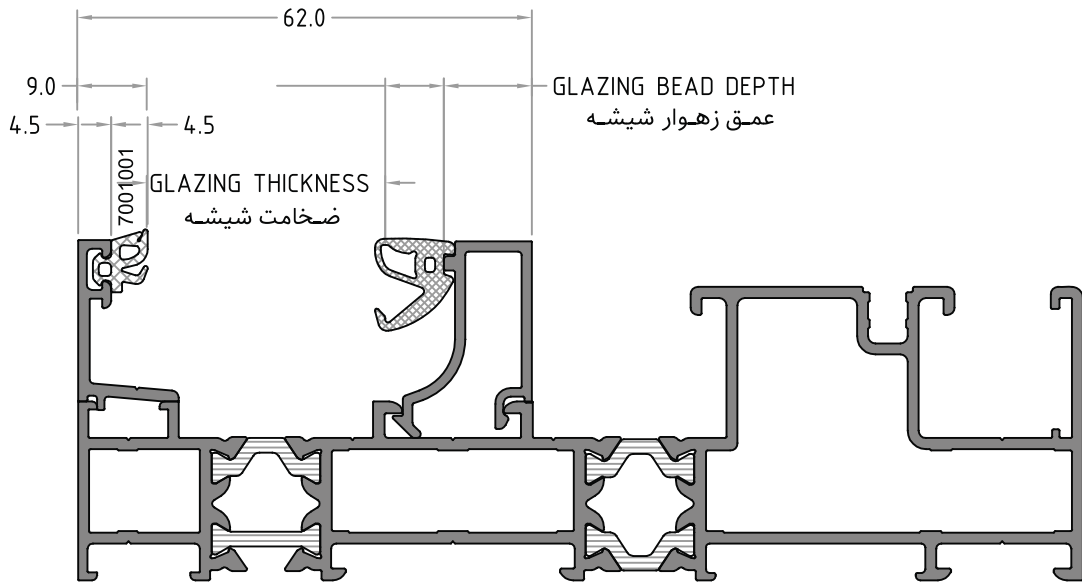

Glazing Thick.	Internal Gasket & Thick.	Glazing Bead & Depth		
ضخامت شیشه	کد و عمق لاستیک	شماره پروفیل و عمق زهوار		
6mm.	7001062	11mm.	1000467	36mm.
8mm.	7001002	9mm.	1000467	36mm.
10mm.	7001005	7mm.	1000467	36mm.
12mm.	7001034	5mm.	1000467	36mm.
14mm.	7001062	11mm.	1000414	28mm.
16mm.	7001002	9mm.	1000414	28mm.
18mm.	7001005	7mm.	1000414	28mm.
20mm.	7001034	5mm.	1000414	28mm.
22mm.	7001062	11mm.	1000405	20mm.
24mm.	7001002	9mm.	1000405	20mm.
26mm.	7001005	7mm.	1000405	20mm.
28mm.	7001034	5mm.	1000405	20mm.
30mm.	7001062	11mm.	1000409	12mm.
32mm.	7001002	9mm.	1000409	12mm.
34mm.	7001005	7mm.	1000409	12mm.
36mm.	7001034	5mm.	1000409	12mm.

INOPEX

Innovated Profile Extrusion

دفتر مرکزی:

تهران، خیابان جلال آل احمد، روبروی شهرآرا
پلاک ۱۴۷، طبقه ۲، واحد ۴ / کد پستی: ۱۴۴۶۶۶۷۵۴۹
تلفن: ۸۸۲۴۶۹۳۱ - ۸۸۲۴۶۹۴۱ (+۹۸۲۱)
فکس: ۸۶۰۱۵۶۰۳ (+۹۸۲۱)

Head Office:

Flat 4, 2nd floor, No. 147, Jalal e Al e Ahmad Highway,
(Opposite ShahrAra), Tehran 1446667549 / IRAN
Tel: (+9821) 88254931 - 88246941
Fax: (+9821) 86015603

w w w . i n o p e x . c o
i n f o @ i n o p e x . c o